

# Centrometal

HEATING TECHNIQUE

Centrometal d.o.o. - Glavna 12, 40306 Macinec, Croatia, tel: +385 40 372 600, fax: +385 40 372 611

## TECHNICAL INSTRUCTIONS

for installation, use and maintenance  
of hot water boiler  
and installation of additional equipment

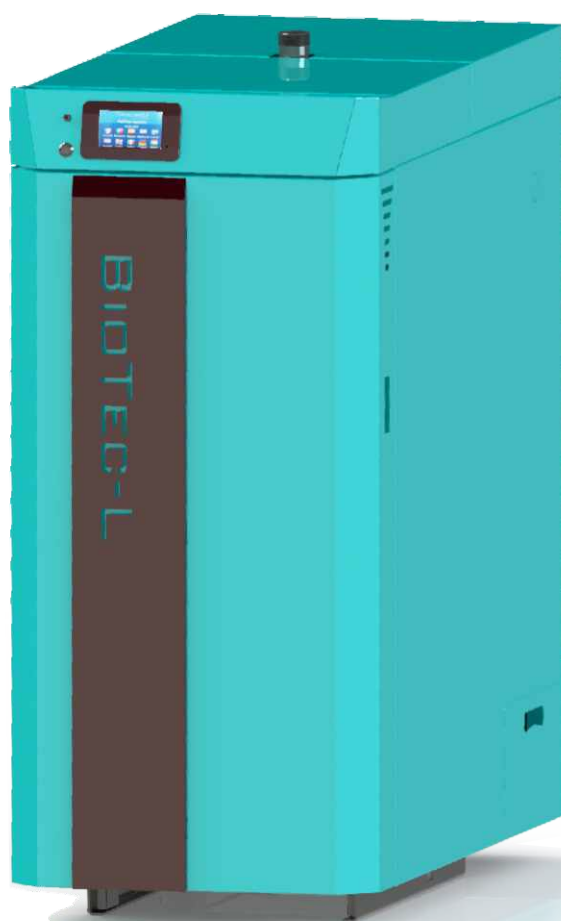

*BioTec-L*

## **Important**

---

These instructions are an integral part of this product. All rights reserved. Reproduction of content of this document and transfer to third parties is not allowed without written approval from manufacturer. Make sure the instructions are always with the device, even if its sale / transfer of another owner to the user or staff authorized for maintenance or repairs to consult.



**READ THESE INSTRUCTIONS CAREFULLY BEFORE INSTALLING THE BOILER TO HEATING SYSTEM!**



**Boiler must not operate in flammable and explosive environment.**



**Boiler must not be used by children or disabled persons (either physically or mentally), as well as by person without knowledge or experience, unless they are under control or trained by s person responsible for their safety. Children must be supervised in the vicinity of the product.**



**Before any work on the boiler, electric energy must be switched off.**

**TECHNICAL DATA**

TIP		BioTec-L	25	34	45
Nominal heat output	(kW)		25	34	45
Heat output range	(kW)		12,5-25	17-34	22,5-45
Boiler class			5		
Required chimney underpressure	(Pa)		8	8	8
Water amount in boiler	(lit.)		115	130	150
Exhaust gas temperature at nominal heat output	(°C)		140		
Exhaust gas temperature at minimal heat output	(°C)		110		
Exhaust mass flow at nominal heat output	(kg/s)		0,019	0,022	0,027
Exhaust mass flow at minimal heat output	(kg/s)		0,010	0,012	0,014
Minimum operating time at rated power (nominal $Q_N$ )	(h)		3,5	4	4
Min. inlet water tem. at the boiler supply water connection	(°C)		60		
Cold water tem. and pressure for safety heat exchanger	(°C/bar)		10-15°C / 2 bar		
Setting range for temperature controller	(°C)		max 90		
Boiler resistance on water side at nominal output	(mbar)		9	11	14
Fuel type			A, wood logs, by norm 14964-5		
Fuel moisture content	(%)		max 25 %		
Fuel size			(450-550) x 70 x 50		
Fuel loading chamber capacity	(lit.)		90	144	176
Fuel loading chamber dimensions (D×W×H)	(mm)		600×250×600	600×400×600	600×400×735
Combustion chamber type			underpressure		
Required minimum accumulation volume (tank) next to boiler			by EN 303:2012-point 4.4.6		
Nominal electrical power input	(W)		135	135	135
Auxiliary power requirements at $Q_N$	(W)		110	116	122
Auxiliary power requirements at $Q_{min}$	(W)		60	67,5	75
Standby power	(W)		5	5	5
Supply voltage	(V~)		230		
Frequency	(Hz)		50		
Current type			~		
Total mass - (boiler with casing and accessories)	(kg)		519	606	677
Max. operating overpressure	(bar)		2,5		
Test pressure	(bar)		5,5		
Max. operating temperature	(°C)		90		
Flue gas tube - external diameter	(mm)		150	160	180
Number of turbulators	(kom.)		8	10	10
Boiler connections	Flow and return pipe (male thread)	(R)	6/4"		
	Charge/discharge (female thread)	(R)	3/4"		
	Heat exchanger connector (male thread)	(R)	3/8"		
	Connector of exchanger sensor (female thread)	(R)	1/2"		
Heating appliance working			with fan		
Heating appliance working			under non-condensing conditions		

**BioTec-L 25 / 34**

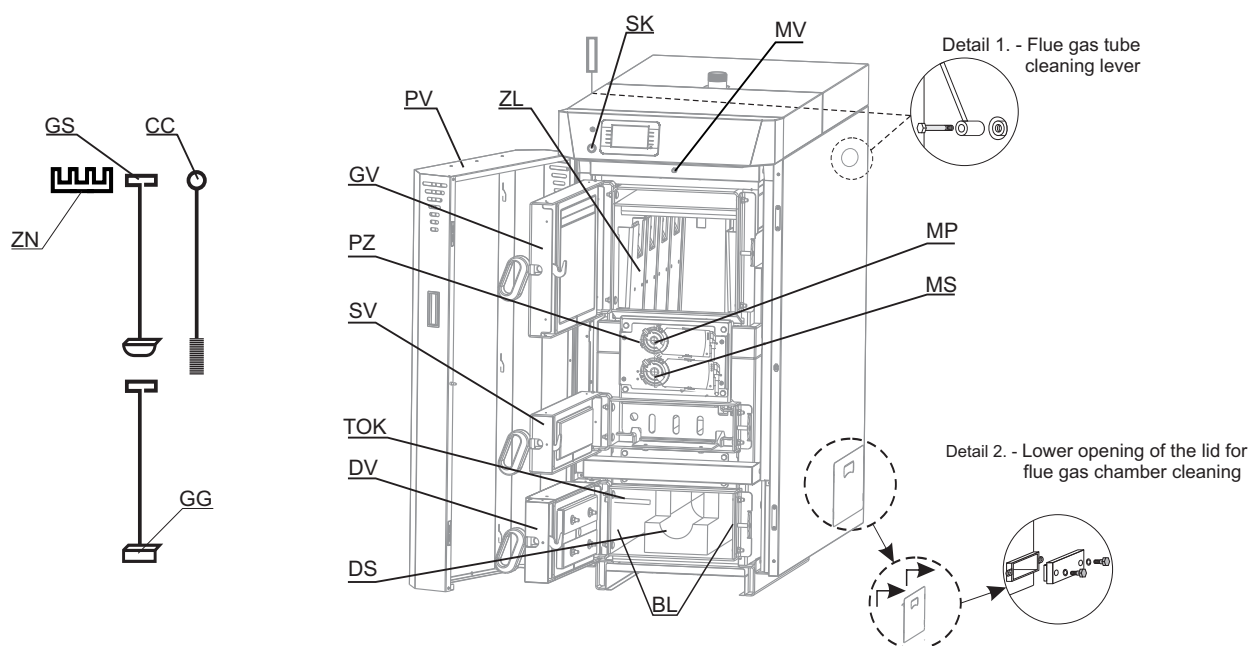
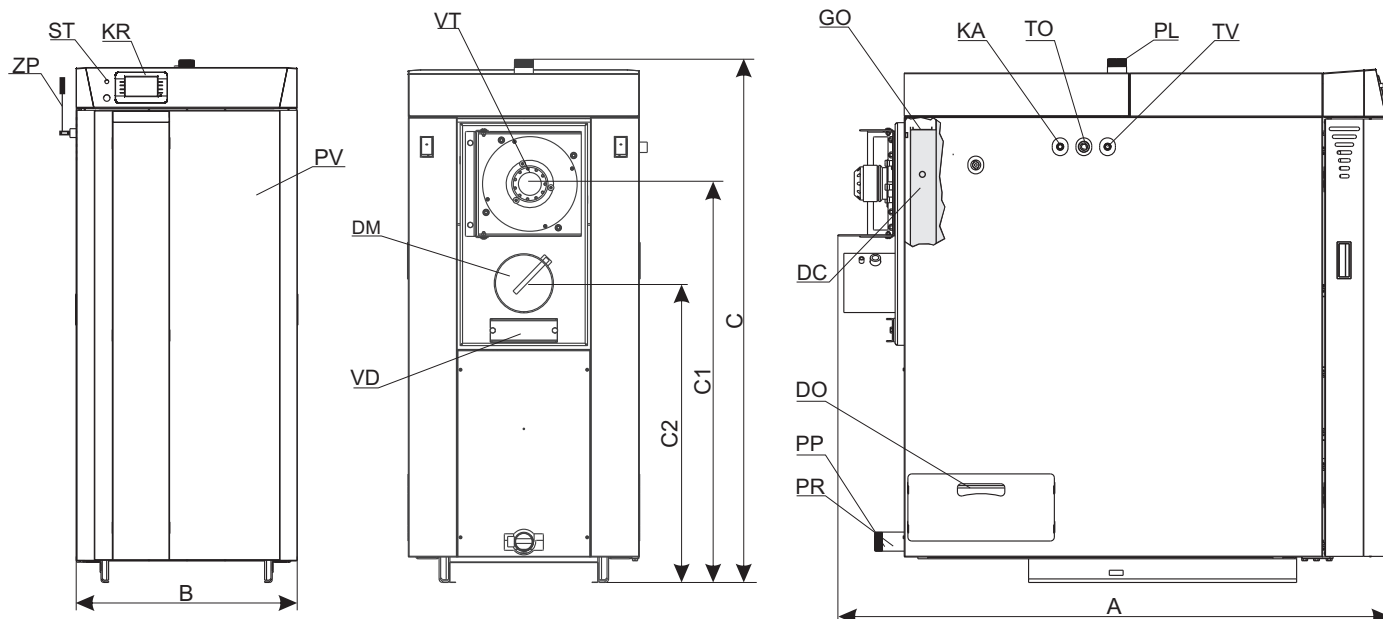

**Boiler body dimensions**

	BioTec-L 25	BioTec-L 34	BioTec-L 45
Width (A)	1400	1370	1385
Depth (B)	585	700	700
Height (C)	1330	1370	1565

**Other dimensions**

Height (C1)	1015	1045	1270
Height (C2)	775	800	1270

**BioTec-L 45**

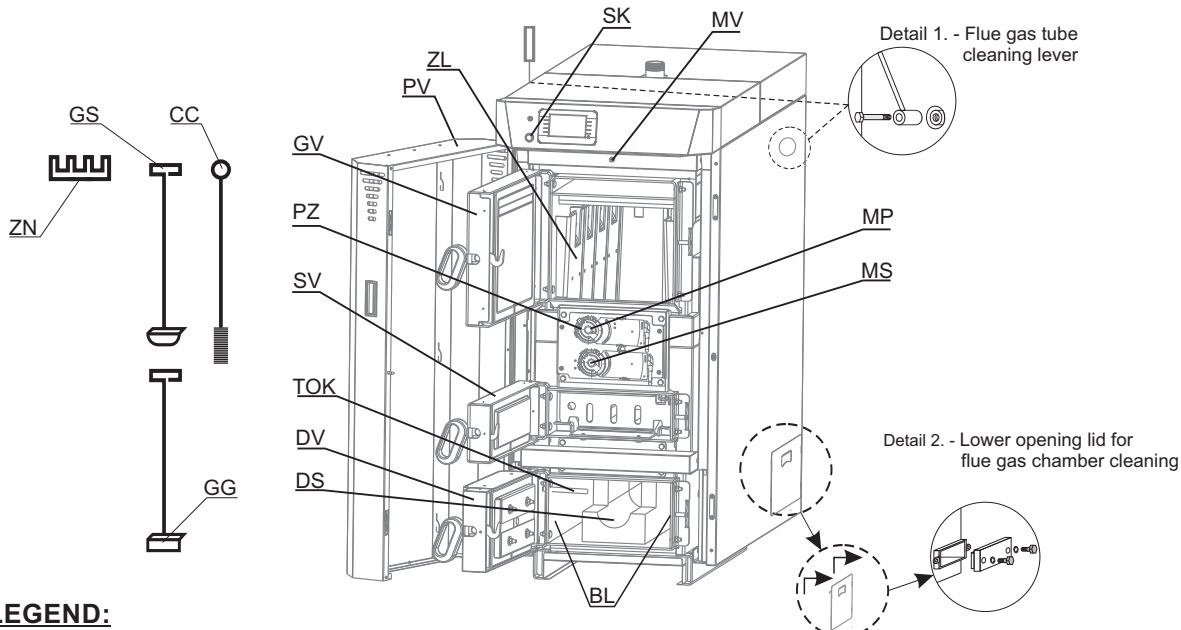
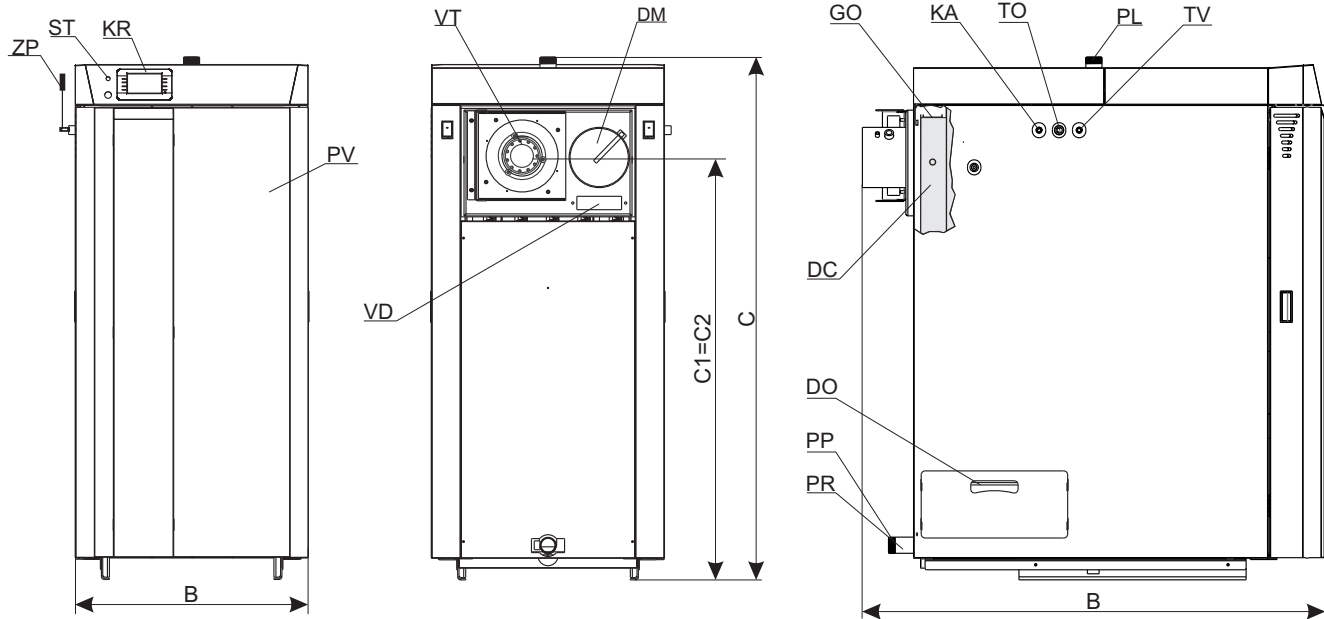

**LEGEND:**

- BL - Lateral sides of bottom chamber
- CC - Flue gas tubes cleaning brush
- DC - Flue gas chamber with tubes and turbulators
- DM - Flue gas tube connection
- DO - Cover of lower openings of the flue gas chamber
- DS - Lower refractory stone (chamotte) (2 parts)
- DV - Lower boiler door
- GG - Scraper for upper refractory stone (chamotte) and flue gas channels cleaning
- GO - Upper opening for flue gas tube cleaning
- GS - Scraper for cleaning of the lower refractory stone (chamotte)
- GV - Upper boiler door
- KA - Heat exchanger connection
- KR - Digital boiler controller
- MP - Primary air actuator
- MS - Secondary air actuator
- MV - Upper door microswitch
- PL - Main flow
- PP - Filling / draining
- PR - Return flow
- PZ - Primary and secondary air opening lid with actuators
- SK - Main switch
- ST - Safety thermostat
- SV - Middle boiler door
- TO - Thermal safety valve sensor connection
- TOK - Tube for combustion chamber sensor
- TV - Heat exchanger connection - thermal safety valve connection point
- VD - Opening for cleaning the flue gas chamber
- VT - Fan
- ZL - Heat metal protecting cover
- ZN - Holder for cleaning set
- ZP - Flue gas tube cleaning lever (can be installed on the left or right boiler side)

### 1.0. GENERAL

Steel hot water boilers **BioTec-L**, nominal heat output 25 to 45 kW, are designed for **wood log** firing, for heating of small and middle sized premises. The wood gasification principle enables a complete fuel burning. Logs up to 550 mm long can be inserted into the large combustion chamber. The burning period of a single fill of logs is up to 4 hours, depend about nominal heat output. The boiler can keep the glow even 12 hours, which means that in this period it is not necessary to fire up the boiler in order to keep the heating process. Boiler operation is controlled with inbuilt boiler control unit using the sensor in combustion chamber, flue gas sensor and lambda probe, motors for primary and secondary air for combustion and modulating underpressure fan on flue gases outlet from boiler. The boiler must be connected to the central heating system with an appropriate number of the CAS water accumulation tanks.

### 1.1. CHARACTERISTICS OF THE BioTec-L BOILER

The BioTec-L boiler is produced in compliance with the EN 303-5:2012 norm, which enables the required level of functioning and minimal environmental pollution, through the firing with wood logs. The boiler is aimed for firing with wood logs. The system of flue gases conduction and their additional burning out, enables its high efficiency, which makes this product extremely economical. Widely sized fuel loading door enables firing with large pieces of wood logs and very simple and easy cleaning and maintenance. One filling of logs lasts up to 4 hours, depend about nominal heat output. There is also a possibility of prolonging the firing process to the entire day, if the heating requirement is decreased. The boiler can keep the glow up to 12 hours, during which period it is not necessary to repeat the start firing process. The flue gas passages are good optimized. The boiler must be connected to the central heating system with return flow protection and with CAS water accumulators. Boiler operation is managed with inbuilt boiler control unit using sensor in combustion chamber, flue gas sensor and lambda probe, motors for primary and secondary air intake for combustion and modulating underpressure fan on flue gases outlet from boiler. Boiler control unit can run return flow protection pump (between boiler and buffer tank) (or 3-way mixing valve with motor drive (protection valve)), buffer tank management, one heating circuit with circulation pump and 3-way mixing valve with actuator steered by outer temperature sensor and room corrector and DHW water heater tank pump. With boiler BioTec-L it is easy to handle, integrated control unit with color touch screen assures reliable and simple boiler operation. With outer temperature sensor, room corrector and control of mixing valve actuator heating system will deliver just right amount of heat to ensure comfort of heating and savings of fuel. With installed accumulation (buffer) tank excess of produced heat is accumulated into the tank and can be consumed when needed. Because of accumulation tank, firing can be planned in a reasonable time, and in the case of mild outside temperature, space heating and DHW heating without firing boiler is also possible for several days. The boiler is delivered together with thermal insulation, covered by a metal casing and it is pre-wired (with boiler sensor, combustion chamber and flue gas sensor, lambda probe, actuators for primary and secondary air intake and flue gas modulating fan).

Concerning the specific need of sanitary hot water, the BioTec-L boiler can be connected to one of water heaters produced by our company. We suggest the combination with wall hanged SKB Digi or LKB Digi water heaters, as well as with floor standing TB water heaters or STEB solar water heaters, if the future connection to the solar system has been planned and also CAS-B or CAS-BS, combination of accumulation buffer tank and stainless steel DHW tank, and solar heat exchanger. The boiler is tested and certified according to the European standard EN 303-5:2012 and meets **class 5**. It is manufactured in compliance with ISO 9001/2008 and ISO 14001/2004 standards.

## 1.2. WOOD GASIFICATION COMBUSTION PROCESS

Combustion process is carried out in double combustion chamber in several phases. After filling the upper chamber with logs, glow dry the logs, and at temperature 100÷300°C logs are being gasified. The gases created in such process are mixed with the oxygen from air and burn out completely with high temperature.

**Fuel:** wood logs with moisture content up to 20% (max. 25%), minimum size must be bigger than a nozzle in refractory stone (chamotte) of the upper chamber. This demand for moisture content is fulfilled with wood dried on air at least 12 months.

## 1.3. DELIVERY PACKAGE

### Delivery package include:

- Boiler BioTec-L (covered with casing with thermal insulation) on wood pallet
- With inbuilt and pre-wired:
  - color touch screen display control unit
  - sensor in combustion chamber
  - flue gas sensor
  - boiler sensor
  - lambda probe
  - 2 actuators for primary and secondary air
  - flue gas modulating fan
- Additional sensors in basic delivery:
  - 2 × Buffer tank sensors
  - 1 × Outer temperature sensor
  - 1 × Main flow sensor / return flow heating circuit sensor / hydraulic crossover sensor
  - 1 × DHW sensor
  - 1 × Room corrector (CSK)
- cleaning brush, two scrapers and holder for cleaning set

## 1.4. ADDITIONAL EQUIPMENT

### 1) OBLIGATORY ADDITIONAL EQUIPMENT:

- accumulation (buffer) tank for heating system (CAS (min. liter according to local regulation))
- return flow protection (like 3-way thermostat valve (60°C) (like ESBE VTC 512, VTC 531, LTC 261, LTC 271) or 3-way mixing valve with motor drive (protection valve).

Recommendations for the VTC valve, circulation pump and water accumulator CAS - according to the boiler output:

Heat output range (kW)	Connection VTC 512 (outer thread)	Connection VTC 531 (internal thread)	Circulation pump type (like Grundfos)	Volume of CAS accumulation tank for Bio-Tec wood gasification boilers
25	5/4"	6/4"	UPS 32-60	Minimum 50 litres / kW of boiler power
34	5/4"	6/4"	UPS 32-60	
45	5/4"	6/4"	UPS 32-60	

Recommendations for the LTC and Laddomat21 units and the water accumulators CAS - according to the boiler output:

Heat output range (kW)	Connection LTC 261 (internal thread)	Connection LTC 271 (internal thread)	Volume of CAS accumulation tank
25, 34	5/4"	--	minimun
45	--	6/4"	50 liters / kW of boiler power

## Additional equipment

---

### For closed heating systems:

- Thermal safety valve
- Safety-airvent group (2,5 bar)
- Expansion vessel for closed heating systems (size according the volume of heating installation, including buffer tank volume)

### For open heating systems:

- Open expansion vessel (size according the volume of heating installation, including buffer tank volume)

### 2) OTHER ADDITIONAL EQUIPMENT (not in basic delivery):

- CAL alarm box (light/speaker)
- CM2K-B module for regulation 2+ heating circuits (max. 4 units) through mixing valve in order to outer temperature.
- CM-GSM alarm/warning module for mobile network (by SMS/CALL).
- Room thermostat

**Room corrector (CSK)  
(basic equipment)  
1 pcs**



**CAL alarm box  
(light/speaker)**



**CM-GSM alarm module  
for mobile network**



**CM2K-B module  
for regulation  
2+ heating circuits**





## 2.0. BOILER / ADDITIONAL EQUIPMENT POSITIONING AND ASSEMBLY

The positioning of the boiler has to be carried out the authorized person. We suggest the positioning on the solid concrete basis, which height is between 50-100 mm. The boiler room has to be absolutely protected from freezing and properly ventilated. The boiler has to be positioned in order to enable its connecting to the chimney (see point 3.) and heating installation as well as its servicing during the functioning process, cleaning and maintenance (Figure 1). The connection of the boiler to the central heating system is obligatory with the one or more **CAS water accumulator buffer tanks**, depending of the boiler's power. It is recommended to connect minimum **50 liters water accumulation to each 1 kW boiler power** (i.e. for the 45 kW boiler minimal water accumulation should be 2.250 liters). The boiler should not be used without being connected to the water accumulation tank. It must be connected to the CAS water accumulator obligatory with **return flow protection** through an 3-way thermic valve (like ESBE VTC 531 (60°C), LTC141(60°C) or Laddomat 21 (63°C)).

### **WARNING!**

**Flammable items must not be placed on the boiler and within the minimum distances shown in Figure 1.**

**Figure 1.** Minimum distance from the boiler room walls

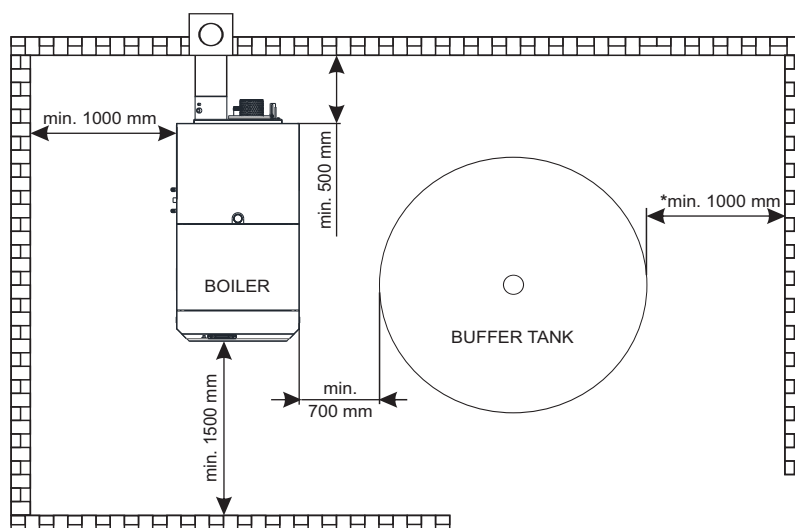

\*valid for closest tank to the wall

## 2.1. INSTALLATION OF DELIVERED PARTS

BioTec-L is delivered on wooden pallet. After the boiler is removed from wooden pallet, should be positioned in the boiler room (see point 2.0.). Base protection with stone wool push under the boiler as shown in figure 2.a.

In upper chamber of the boiler are delivered (figure 2.b):

1. holder for cleaning set and 2 cleaning scrapers and cleaning brush
2. room corrector and sensors (2 buffer tanks sensors, 1 main flow sensor, 1 DHW sensor, 1 outer sensor)
3. Ashtray

Holder for cleaning set can be positioned on lateral side of the boiler (A) or to the wall (B), near the boiler and easy accessible. On this holder should be placed cleaning set (2 scrapers and brush).

Sensors and room corrector should be connected according heating installation and connecting scheme.

Figure 2.a Base protection with stone wool

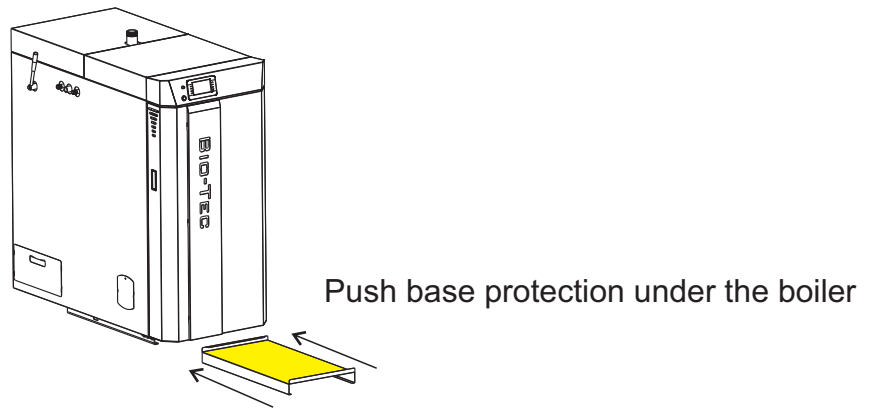
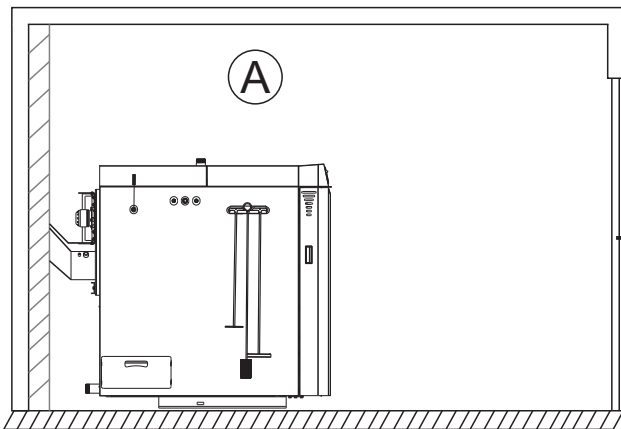
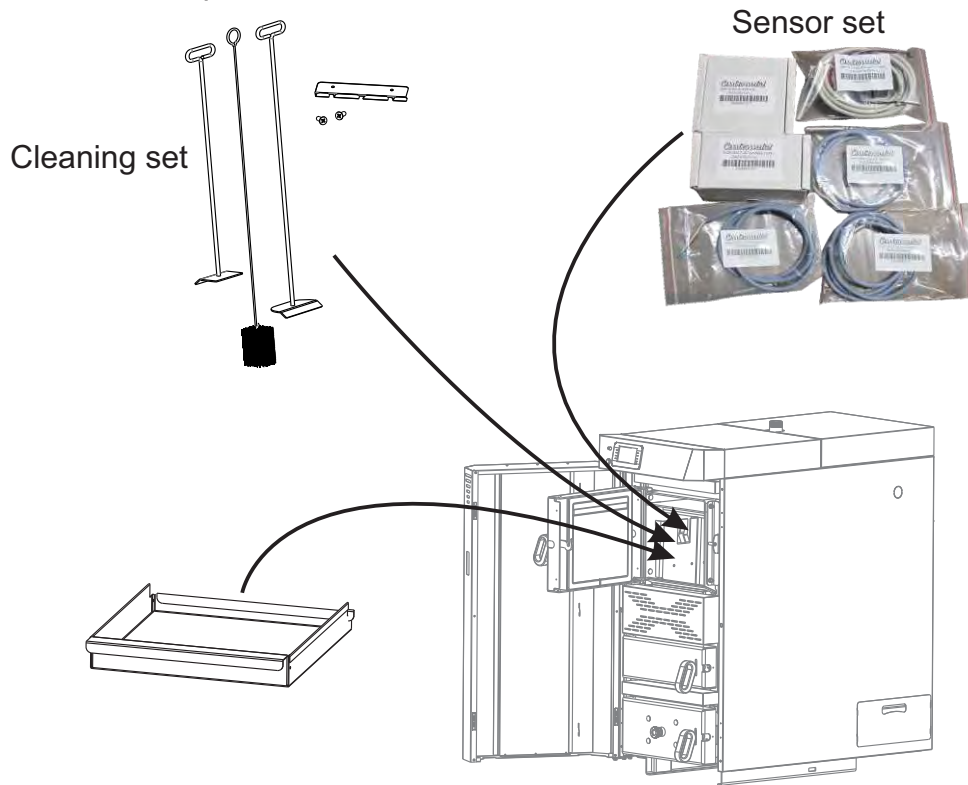
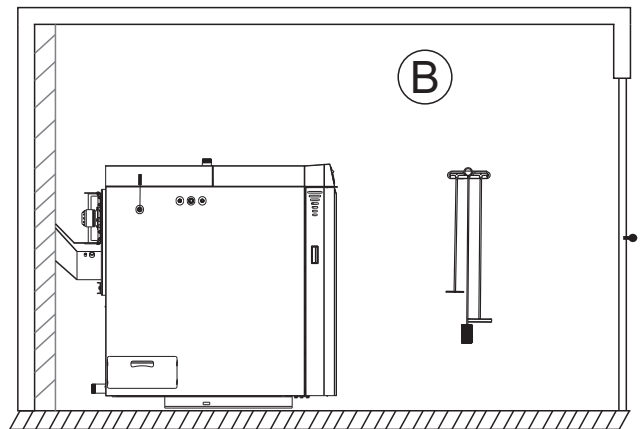

Figure 2.b Delivered parts



Position of cleaning set - on the boiler.



Position of cleaning set - on the wall.

### 3.0. CONNECTION TO THE CHIMNEY

Properly dimensioned and built chimney is the precondition for a safe and reliable operation of the boiler and economic heating. The chimney has to be good insulated, gas-proof and smooth. On the lower part of the chimney, a cleaning door has to be built in. Brick layed chimney has to have 3 layers with an stone wool thermal insulation in the middle. The thickness of the insulation should be 30 mm, if the chimney is situated inside the building, i.e. 50 mm if the chimney is situated outside the building. **Inside chimney diameter dimensions depend on its height and on the boiler thermal output (Figure 5.).** The temperature of the flue gases on chimney exit point should be minimum 30°C higher then the temperature of their condensating point. The choice and the construction of the chimney should be performed by an authorized person. Minimal distance between boiler and the chimney is 500 mm. The flue gas tube has to have an inclination of 30-45° to the chimney (Figure 3.). In order to unale entering of the condensate from the chimney into the boiler, 10 mm of the flue gas tube length has to be inserted deaper inside the chimney. **It is obligatory to insulate the chimney connection tube with a mineral stone wool of 30-50 mm thickness.** All installation works must be made in accordance with valid national and European standards.

Figure 3. - Possible connecting of the BioTec-L boiler to the chimney

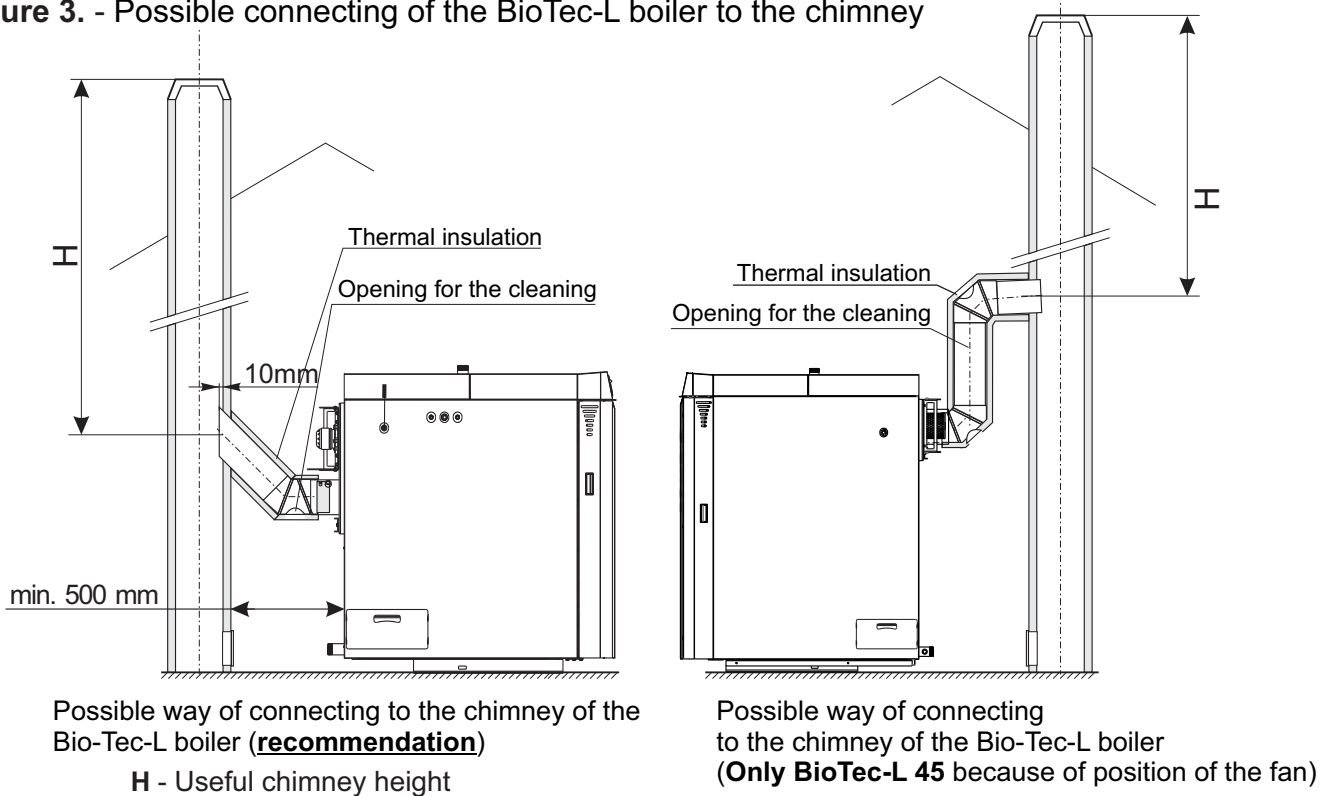

At connecting a boiler to the chimney, flue gas tubes and elbows must not pass behind the fan since in that case the cleaning and maintenance will not be possible. An example of incorrect position of flue gas tubes and elbows in relation to the fan is presented at the Figure 4.

**Figure 4.** Incorrect connecting the boiler to the chimney - not possible cleaning of the fan

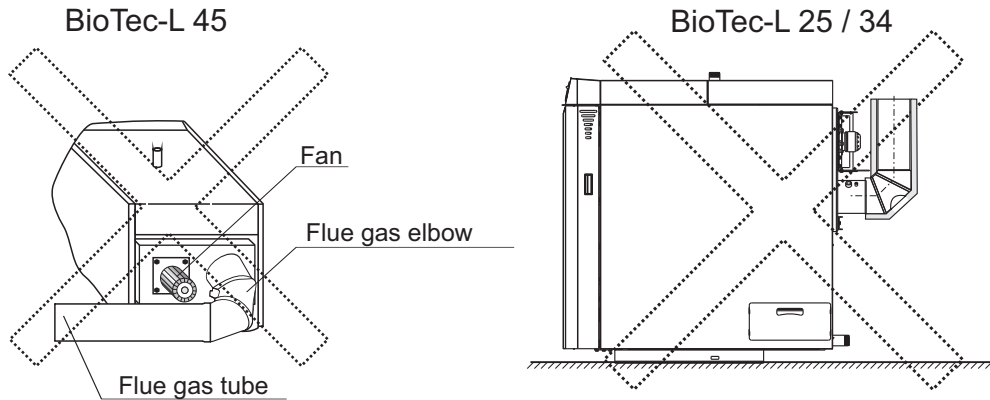

**Figure 5.** - Dimensioning of the chimney for BioTec-L boilers

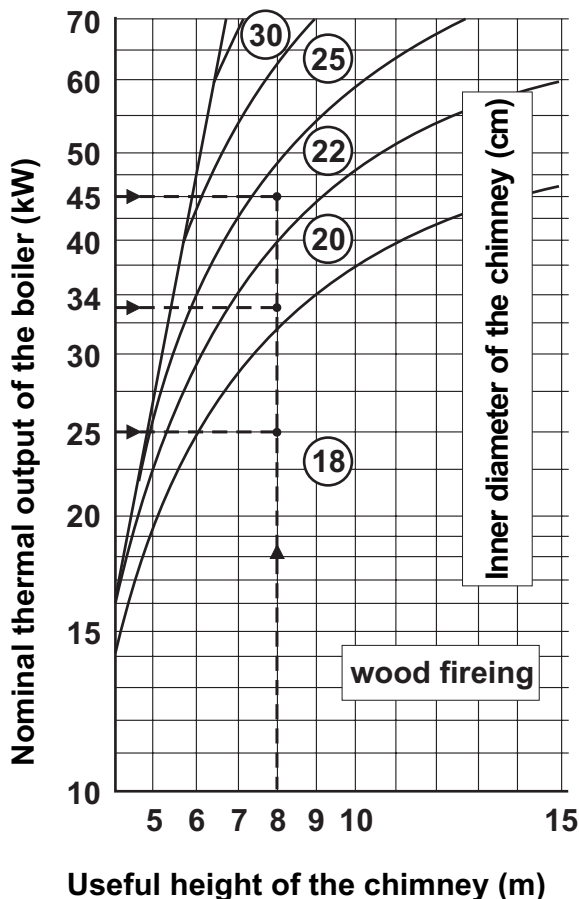

### An example of the chimney selection:

- **boiler output: 25 kW**
- Fuel: wood logs
- required useful chimney height: H=8 m
- required inner chimney diameter: 18 cm
  
- **boiler output: 34 kW**
- Fuel: wood logs
- required useful chimney height: H=8 m
- required inner chimney diameter: 20 cm
  
- **boiler output: 45 kW**
- Fuel: wood logs
- required useful chimney height: H=8 m
- required inner chimney diameter: 22 cm

**Useful chimney height** - from flue gas tube connection to the top of chimney

**Inner chimney diameter** - interior chimney diameter.

#### 4.0. FRESH AIR OPENING

Boiler room **must be equipped with an opening** for supply of fresh air which is dimensioned in accordance with boiler thermal output (minimum opening area according to below shown equation). Such opening must be protected with a net or grate. All installation works have to be performed in accordance with valid national and European standards. Boiler must not operate in flammable and explosive environment.

$$A = 6,02 \times Q$$

A - opening area in cm<sup>2</sup>  
Q - boiler output in kW

#### 5.0. BOILER THERMAL PROTECTION

According to European EN standards, boiler thermal protection **must be** installed in **closed** heating system. Boiler is factory prepared for installation of thermal protection. Heat exchanger is factory built into boiler, and thermal safety valve **7** should be installed according to Scheme 3. In case of any damage of boiler installed in the closed heating system due to its overheating, and boiler or system are not equipped with any thermal protection at all, or do not have properly installed thermal protection, guarantee will not be applied.

##### **IMPORTANT:**

Thermal protection must be connected to the water supply installation of the premises supplied from the public water supply line and not from hydrophor. Namely, in case of failure of power supply, boiler could be overheated, and then hydrophor is not able to ensure required water supply.

##### **THERMAL PROTECTION:**

Thermal protection for boiler Bio-Tec-L consists of a **heat exchanger** which is factory built in boiler, and **thermal safety valve 7** (such as CALEFFI 543 513) (see Scheme 1).

Part **7** is installed into prepared connector (male thread 3/4") in the upper part of left lateral side of the boiler casing.

##### **INSTALLATION** (see Scheme 3.)

- screw the thermal safety valve sensor **6** (outer thread 1/2") into the sleeve joint **2** (inner thread 1/2").
- fix the connection **4** (inner thread 3/4") of the thermal safety valve to the sanitary cold water inlet and the connection **5** (inner thread 3/4") to the connection point of the heat exchanger **1** (outer thread 1/2") - the arrow shows the direction.
- fix the tube connected to the sewage outlet at the connecting point **3** (outer thread 1/2").

Scheme 1. - Thermal protection in an closed heating system

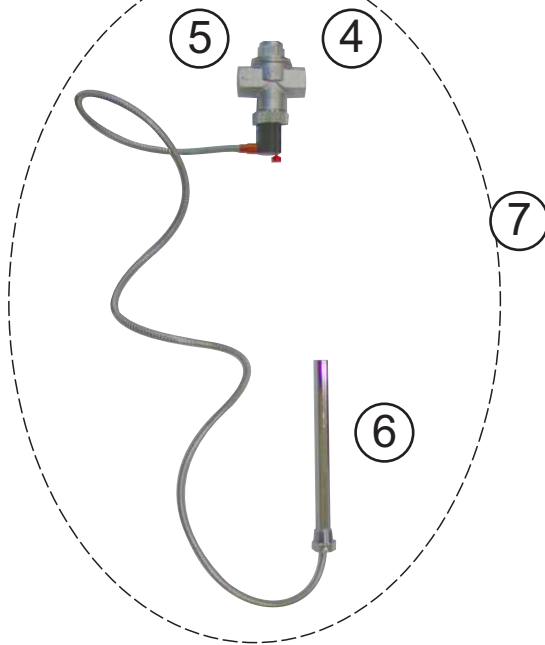

- ① - Heat exchanger connection (to thermal safety valve)
- ② - Connection for the thermal safety valve sensor
- ③ - Heat exchanger connection (to the sewerage)
- ④ - Thermal safety valve connection (cold water inlet HV)
- ⑤ - Thermal exchanger connection (to the boiler) (to the boiler)
- ⑥ - Thermal safety valve-sensor
- ⑦ - Thermal safety valve
- ⑧ - Dirt filter (recommended)

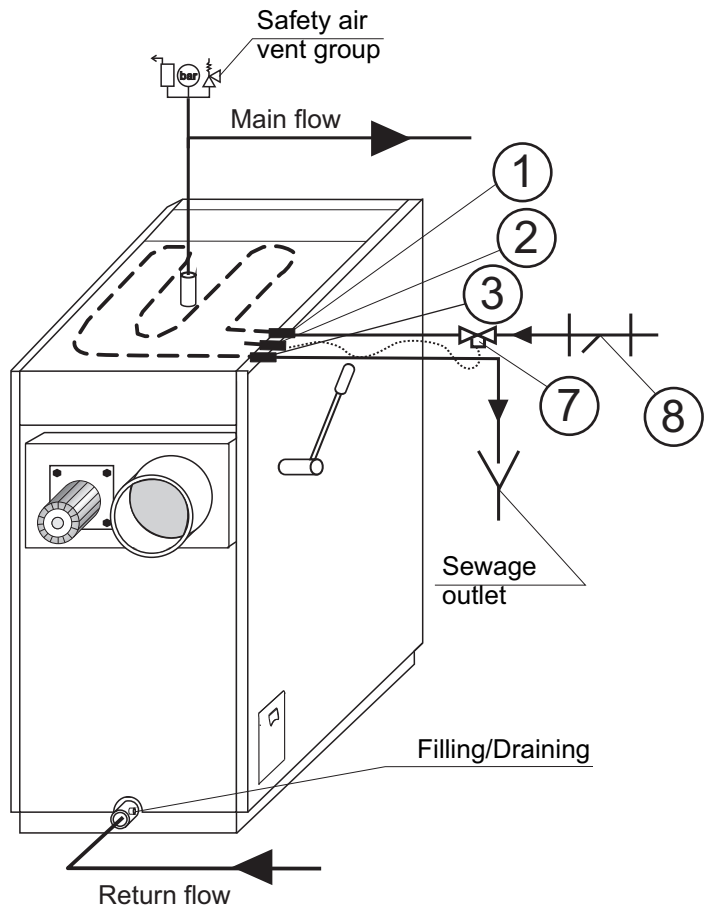
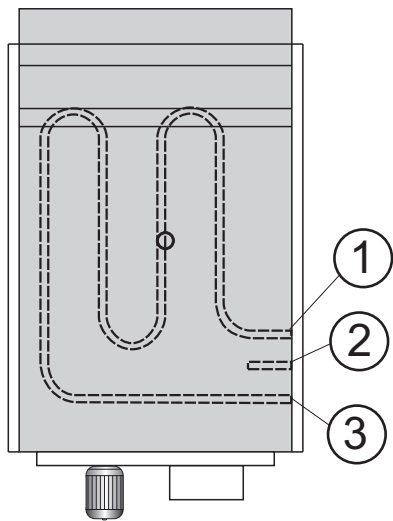

## 6.0. CONNECTION TO THE CENTRAL HEATING SYSTEM

All installation works must be made in accordance with valid national and European standards. Boiler BioTec-L can be built to closed and open central heating system. In both cases boiler must be fired with wood logs. Installation has to be made in according to technical standards, by a professional who will be responsible for proper boiler operation. The main flow pipe from the boiler to the central heating system must not pass above the top back casing cover (PD), otherwise the removal of the turbulators and cleaning of flue gas tubes is impossible (see Figure 6). Before connecting boiler to central heating system, the system has to be flushed to remove impurities remaining after system installation. It prevents boiler overheating, noise within the system, disturbances at a pump and mixing valve. Boiler should always be connected to central heating system by connectors, never by welding. Figure 1. shows minimum distances required for boiler cleaning and maintenance.

**Figure 6.** Examples of main flow constructions

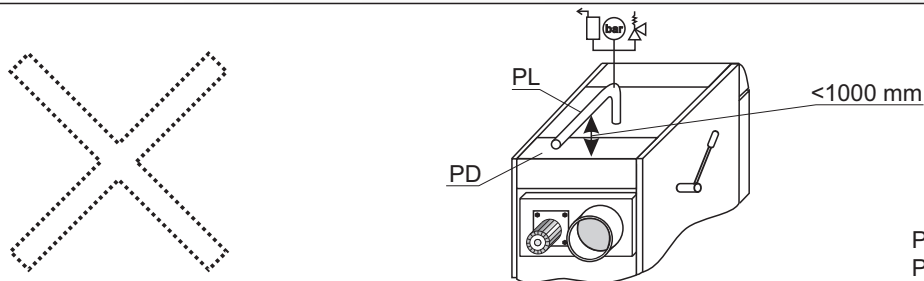
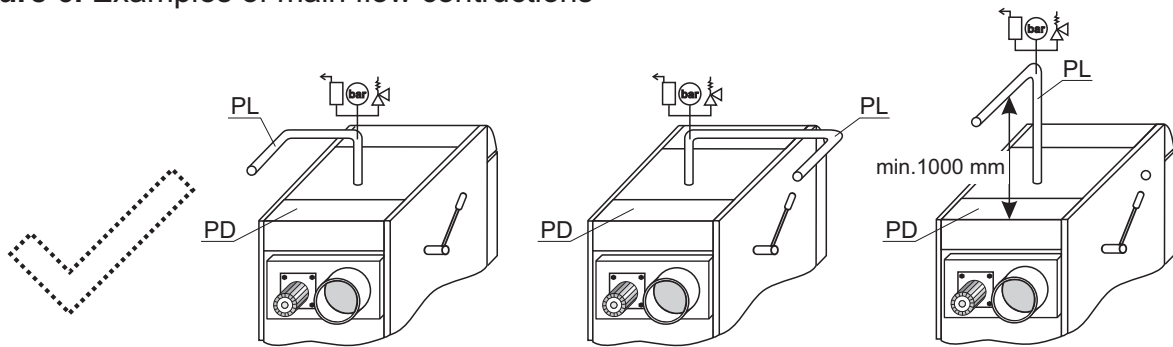

PD - Top back casing cover  
PL - Main flow

**Scheme 2a.** - Basic scheme for boiler installation on closed central heating system with return flow protection with thermic valve (group) (electrical connections and sensor are not drawn, for details see general schemes)

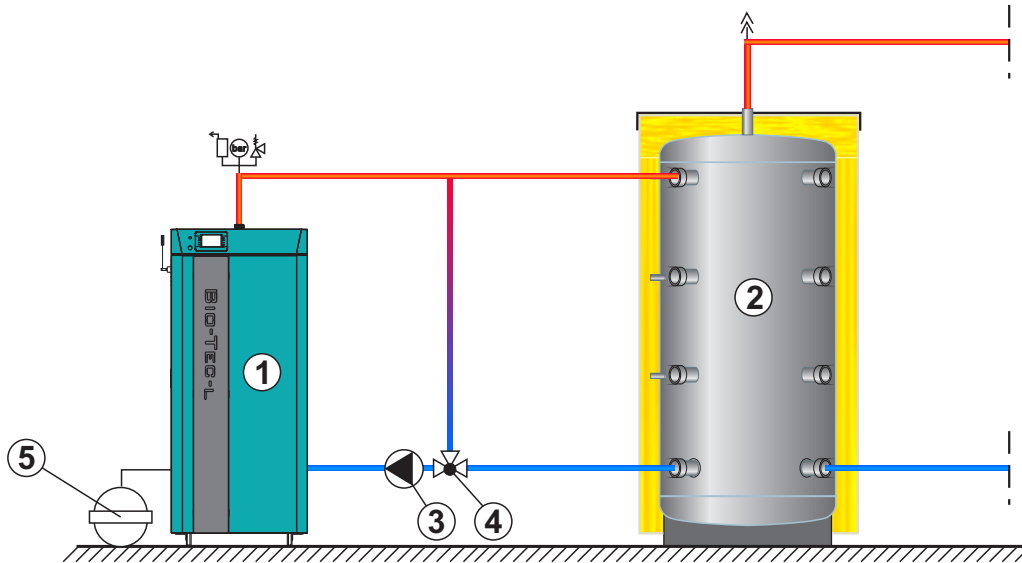

**Scheme 2b.** - Basic scheme for boiler installation on open central heating system with return flow protection with thermic valve (group) (electrical connections and sensors are not drawn, for details see general schemes)

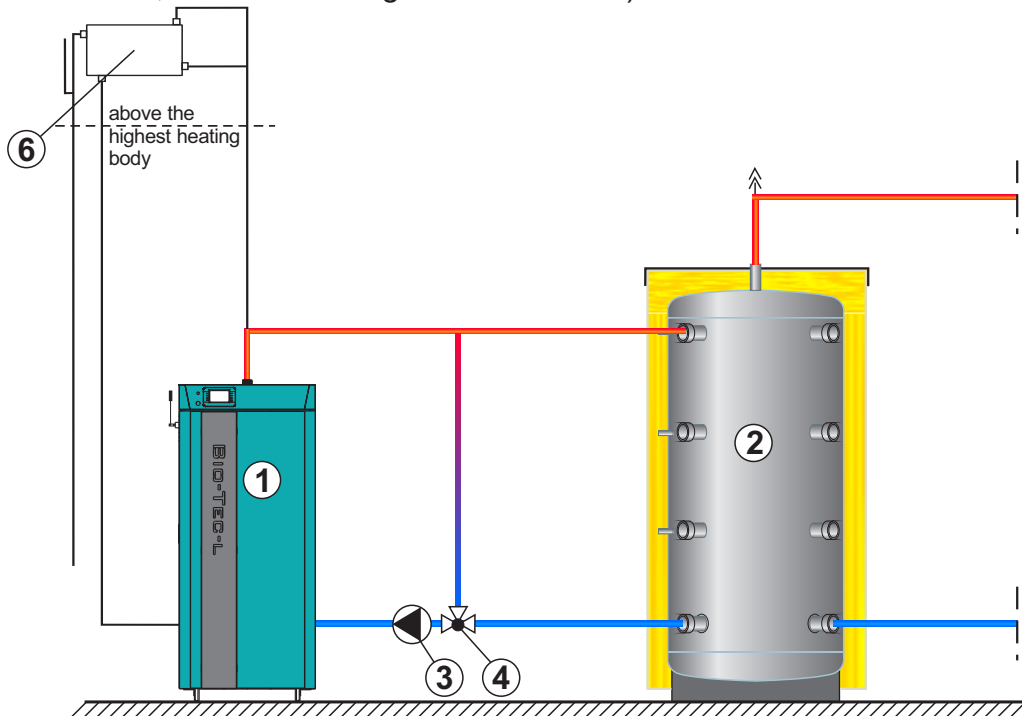

- ① - Boiler BioTec-L
- ② - Accumulation tank «CAS»
- ③ - Boiler pump
- ④ - Return flow protection 3-way thermic valve (like Esbe LTC, VTC..., 60°C) or 3-way mixing valve with motor drive (protection valve)
- ⑤ - Expansion vessel for closed heating systems (approx. 10% of the total volume of installation)
- ⑥ - Open expansion vessel for open heating systems (OPC) (approx. 7% of total volume of installation)



### 6.1. CONNECTION TO THE OPEN CENTRAL HEATING SYSTEM

If the boiler is aimed to be integrated into an open central heating system, one of possible way how to connect the boiler to the system is shown on Scheme 2b. In case of BioTec-L boilers, the boiler pump obligatory **has to be** connected to the boiler control unit, in order to make turning on and off of the pump depending on the temperature of the water in the boiler, to avoid boiler condensation. The functioning of boiler control unit is shown in Technical manual "Digital boiler control unit BioTec-L".

Connection to an open central heating system requires the implementation of an open expansion vessel (OPC) above the level of the highest heating body (radiator). If the expansion vessel is situated inside the non heated room, it has to be insulated. The volume of the open expansion vessel is about 7% of the volume of entire heating installation. The boiler **has** to be connected with one or more CAS water accumulators, depending on its nominal power. It is recommended to connect minimum 50 liters water accumulation to each 1 kW boiler nominal power (i.e. for the 45 kW boiler minimal water accumulation should be 2250 liters) and always check the local regulation about the needed minimum volume. The boiler should not be used without being connected to the water accumulation tank with needed min. volume. It must be connected to the CAS water accumulator obligatory through an 3-way thermic valve like Esbe VTC 512 (60°C), VTC 531 (60°C), load unit LTC 261/271 (60°C), load unit Laddomat 21 (63°C) or 3-way mixing valve with motor drive (protection valve).

### 6.2. CONNECTION TO THE CLOSED CENTRAL HEATING SYSTEM

In closed heating system (as in example shown in Scheme 2a) it is **obligatory** to build in certified safety valve with opening pressure of 2,5 bar, minimum seat diameter of 15 mm, minimum inlet connection of 1/2", minimum exit connection of 3/4" and a membrane expansion vessel. Safety valve and expansion vessel must be built in accordance with professional rules and any valve must not be located between safety valve and expansion vessel and boiler. The closed heating system must have the installed expansion vessel of larger volume (vessel volume must be approx. 10% of the heating installation volume). In all boiler types the heating pump **must be** connected to boiler control unit so that the heating pump switching on and off would depend on water temperature in the boiler. The functioning of boiler regulation is shown in Technical manual "Digital boiler regulation BioTec-L".

The boiler has to be connected with one or more CAS water accumulators, depending of its power. It is recommended to connect 50 liters water accumulation to each 1 kW boiler power (i.e. for the 45 kW boiler minimal water accumulation should be 2250 liters). The functioning of boiler control unit is shown in Technical manual "Digital boiler control unit BioTec-L". The boiler should not be used without being connected to the water accumulator. It must be connected to the CAS water accumulator obligatory through an 3-way thermic valve like Esbe VTC 512 (60°C), VTC 531 (60°C), load unit LTC 261/271 (60°C) or load unit Laddomat 21 (63°C) or 3-way mixing valve with motor drive (protection valve).

**6.3. GENERAL CONNECTION SCHEMES**

**Scheme 3. - General scheme of closed central heating system with 2 or more accumulation tanks.**

- \*1 - Boiler "BioTec-L"
- 2 - "CAS" accumulation tank (buffer tank)
- \*3 - Return flow protection (3-way thermic valve (60°C), VTC 531, LTC 261/271, Laddomat 21 or 3-way mixing valve with motor drive (protection valve))
- \*4 - Safety airvent unit
- \*5 - Expansion vessel for closed systems (min. 10% of the total volume of installation)
- \*6 - Thermal safety valve

- \*P1 - PumpP1 (boiler pump)
- A - Accumulation tank sensor (upper)
- B - Accumulation tank sensor (lower)
- D - Outer temperature sensor
- E - Flue gas sensor

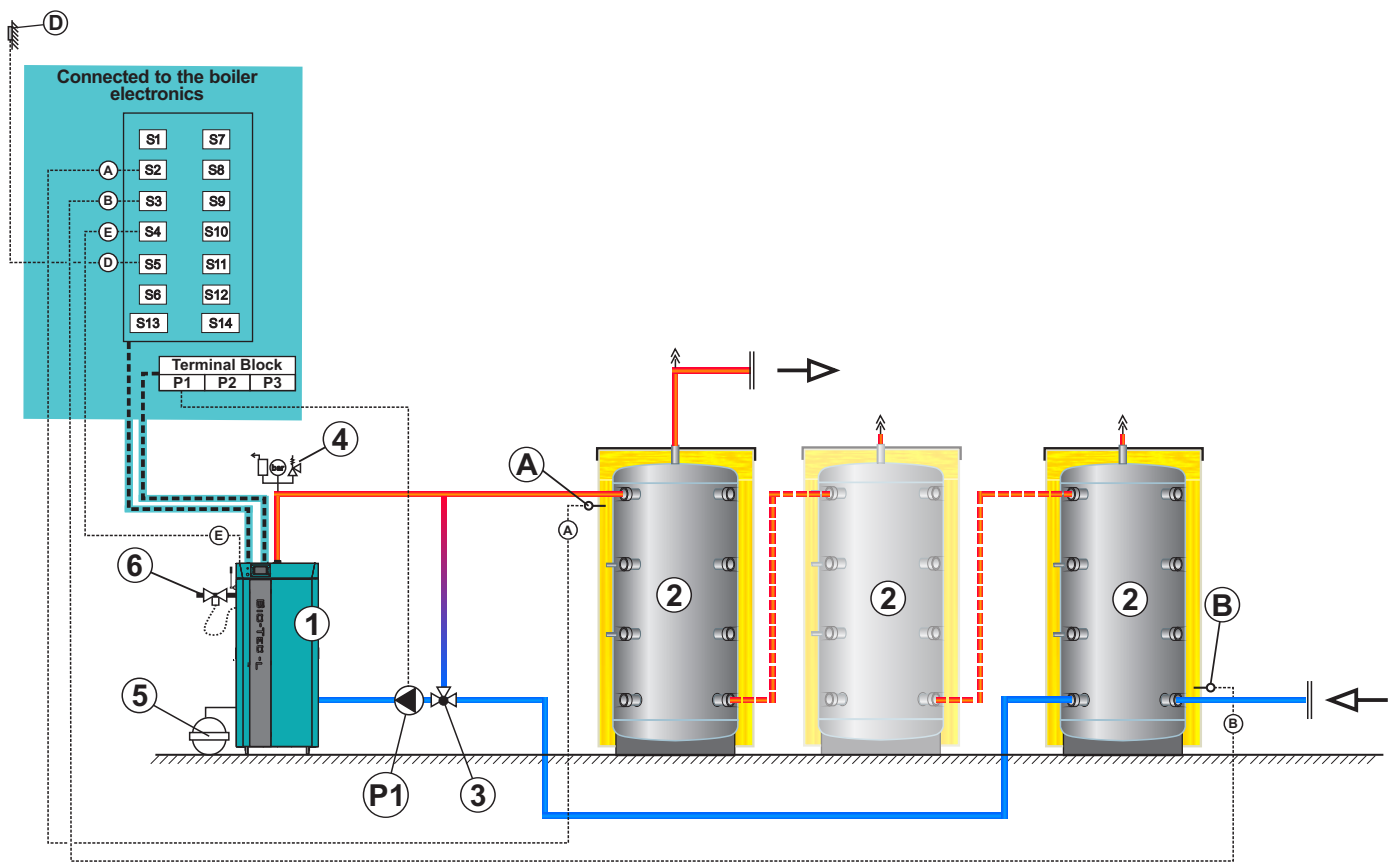

\* Not included in delivery of boiler Biotec-L (need additional order)

**All general schemes hereafter will be shown with one accumulation tank, but they can be performed with two or more accumulation tanks (buffer tanks).  
Pay attention to electrical and sensors connections on general schemes!**

**Scheme 4.** - General scheme of closed central heating system with 1 accumulation tank, heating system behind accumulation tank, 1 heating circuit with 3-way mixing valve with motor drive, and DHW preparation.

- 1 - Boiler "BioTec-L".
- \*2 - "CAS" accumulation tank (buffer tank).
- \*3 - Return flow protection (3-way thermic valve (60°C), VTC 531, LTC 261/271, Laddomat 21 or 3-way mixing valve with motor drive (protection valve))
- \*4 - Expansion vessel for closed systems (min. 10% of the total volume of installation)
- \*5 - Sanitary water tank (SKB-Digi/LKB-Digi/TB/STEB)
- \*6 - Safety airvent unit
- \*7 - Thermal safety valve

- \*P1 - Pump P1 (boiler pump)
- \*P2 - Pump P2 (DHW pump)
- \*P3 - Pump P3 (heating pump)
- A - Accumulation tank sensor (upper)
- B - Accumulation tank sensor (lower)
- C - DHW sensor (domestic hot water)
- D - Outer temperature sensor
- E - Flue gas sensor
- F - Main flow sensor
- \*G - 3-way mixing valve with motor drive or manual 3-way mixing valve
- H - Room corrector (CSK)
- \*I - Heating circuit

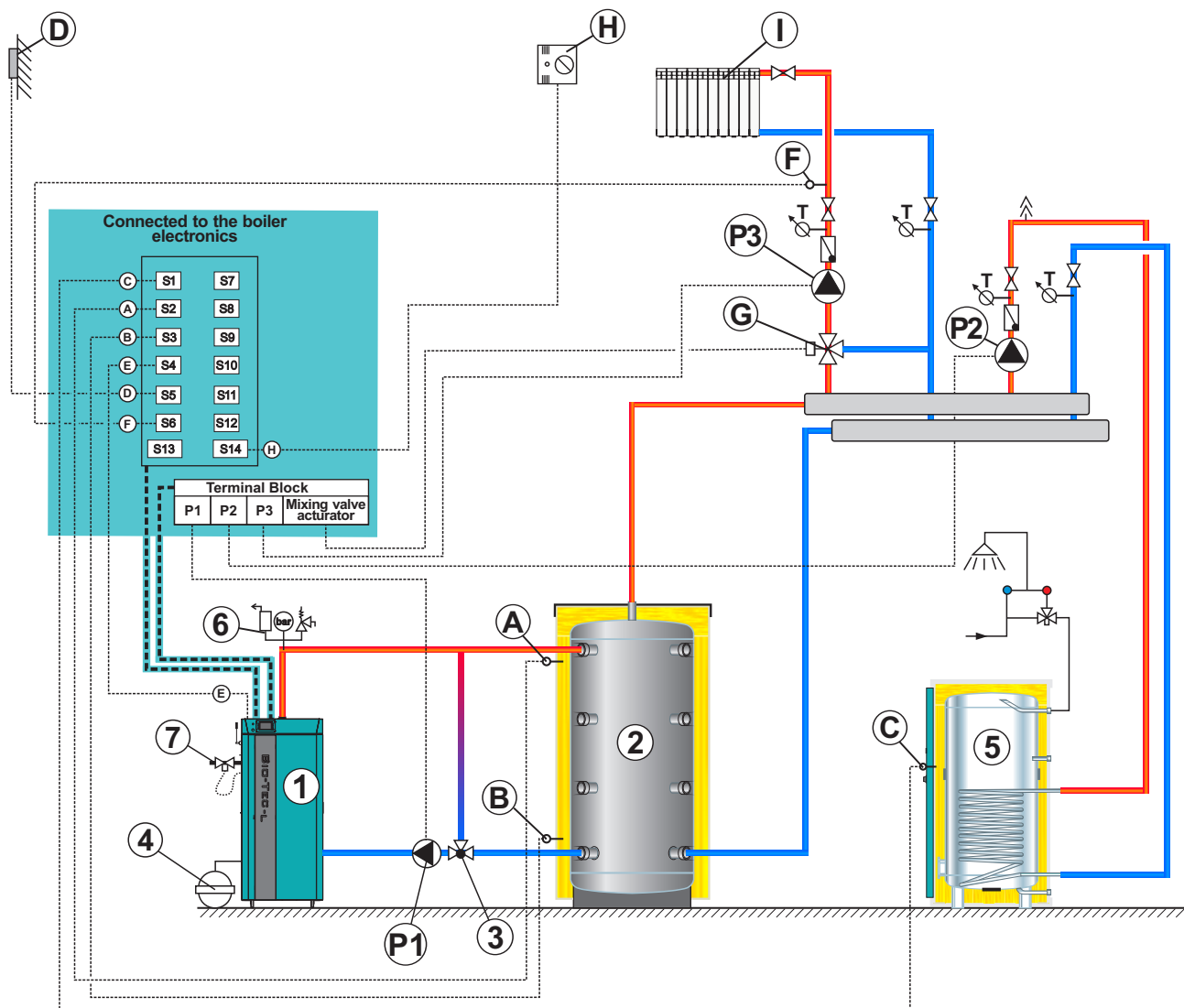

\* Not included in delivery of boiler Biotec-L (need additional order)

**NOTE:**

According to this scheme is possible to preform version for open central heating system (see point 6.0, Connection to the central heating system).

## Scheme 5. - General scheme of closed central heating system with 1 accumulation tank, heating system in front of accumulation tank, 1 heating circuit with 3-way mixing valve with motor drive, room corrector, and DHW preparing.

- 1 - Boiler "BioTec-L".
- \*2 - "CAS" accumulation tank (buffer tank).
- \*3 - Return flow protection (3-way thermic valve (60°C), VTC 531, LTC 261/271, Laddomat 21 or 3-way mixing valve with motor drive (protection valve))
- \*4 - Expansion vessel for closed systems (min. 10% of the total volume of installation)
- \*5 - Sanitary water tank (SKB-Digi/LKB-Digi/TB/STEB)
- \*6 - Safety airvent unit
- \*7 - Thermal safety valve

- \*P1 - Pump P1 (boiler pump)
- \*P2 - Pump P2 (DHW pump)
- \*P3 - Pump P3 (heating pump)
- A - Accumulation tank sensor (upper)
- B - Accumulation tank sensor (lower)
- C - DHW sensor (domestic hot water)
- D - Outer temperature sensor
- E - Flue gas sensor
- F - Main flow sensor
- \*G - 3-way mixing valve with motor drive or manual 3-way mixing valve
- H - Room corrector (CSK)
- \*I - Heating circuit

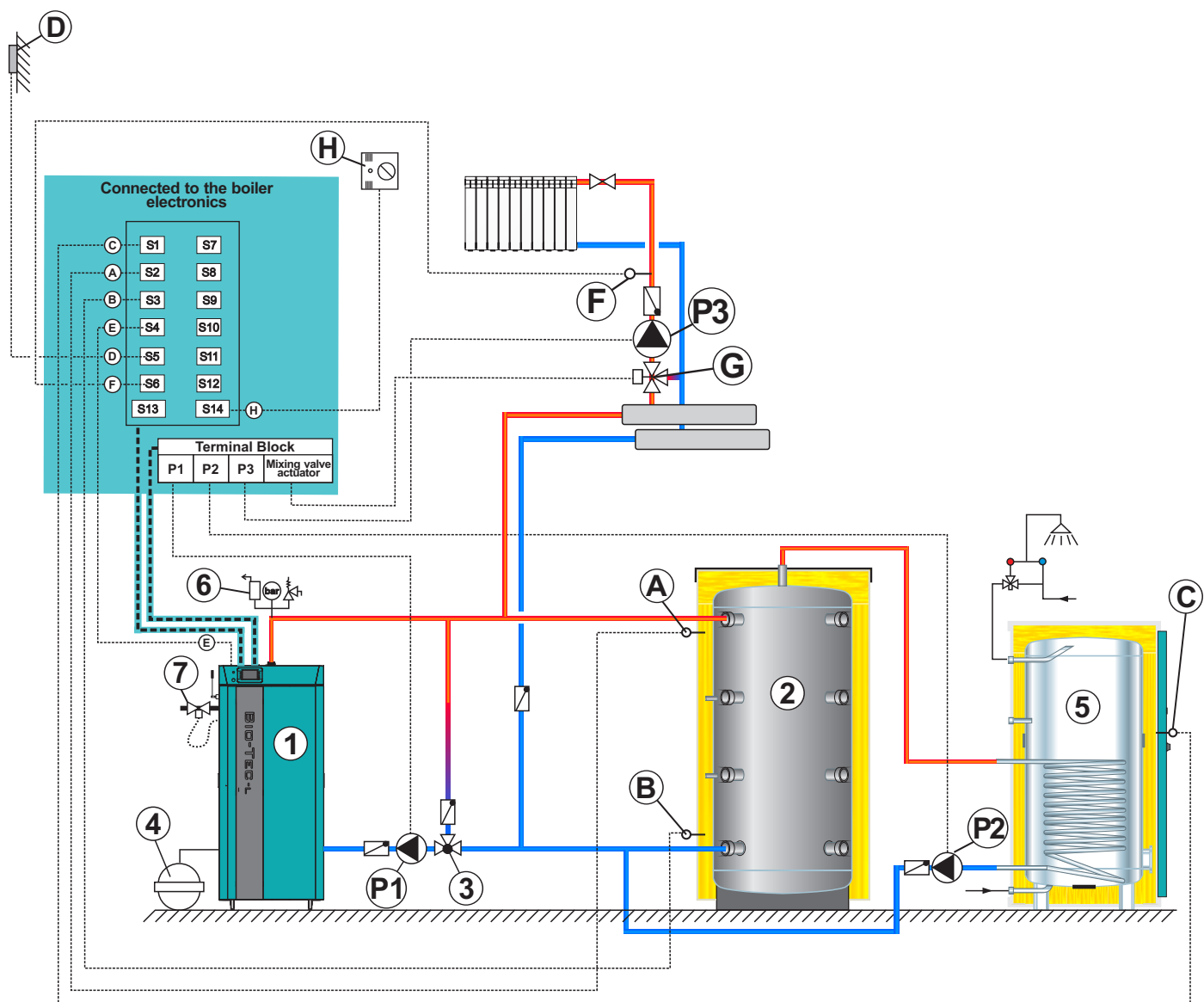

\* Not included in delivery of boiler Biotec-L (need additional order)

### NOTE:

According to this scheme is possible to preform version for open central heating system (see point 6.0, Connection to the central heating system).

**Scheme 6.** - General scheme of closed central heating system with 1 accumulation tank, boiler return flow protection with 3 - way mixing valve with electric actuator.

- 1 - Boiler "BioTec-L".
- \*2 - "CAS" accumulation tank (buffer tank).
- \*3 - Return flow protection (3-way mixing valve with motor drive (protection valve))
- \*4 - Expansion vessel for closed systems (min. 10% of the total volume of installation)
- \*5 - Safety airvent unit
- \*6 - Thermal safety valve

- \*P1 - Pump P1 (boiler pump)
- A - Accumulation tank sensor (upper)
- B - Accumulation tank sensor (lower)
- C - Return flow temperature sensor
- D - Outer temperature sensor
- E - Flue gas sensor

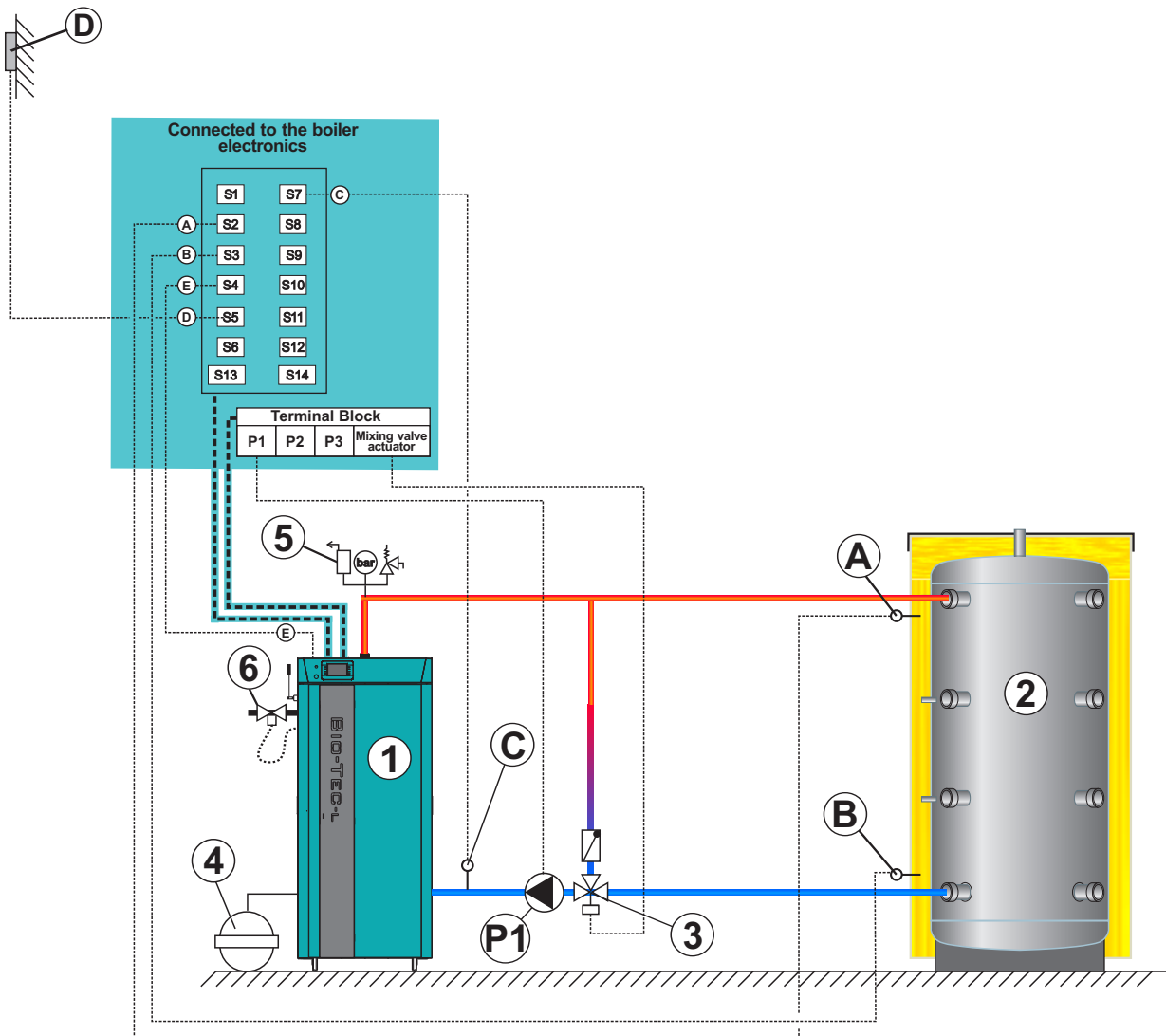

\* Not included in delivery of boiler Biotec-L (need additional order)

**NOTE:**

According to this scheme is possible to preform version for open central heating system (see point 6.0, Connection to the central heating system).

**Scheme 7.** - General scheme of closed central heating system with 1 accumulation tank, boiler return flow protection with 3 - way mixing valve with electric actuator, and DHW preparing.

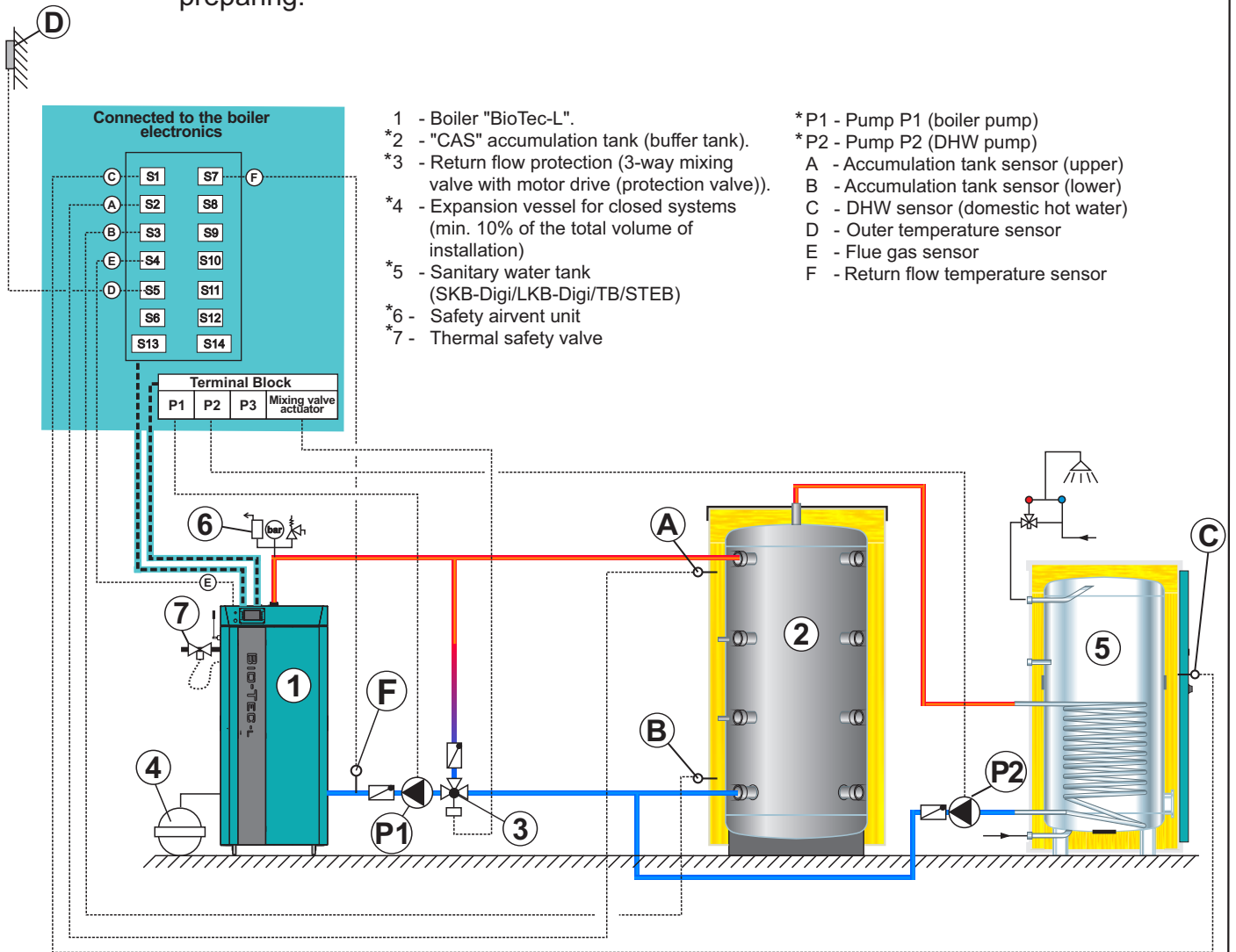

\* Not included in delivery of boiler Biotec-L (need additional order)

**NOTE:**

According to this scheme is possible to preform version for open central heating system (see point 6.0, Connection to the central heating system).

**Scheme 8.** - General scheme of closed central heating system with 1 accumulation tank, heating system behind accumulation tank, 2 heating circuit with 3-way mixing valve (one with motor drive, other manually operated).

- 1 - Boiler "BioTec-L".
- \*2 - "CAS" accumulation tank (buffer tank).
- \*3 - Return flow protection (3-way thermic valve (60°C), VTC 531, LTC 261/271, Laddomat 21 or 3-way mixing valve with motor drive (protection valve))
- \*4 - Expansion vessel for closed systems (min. 10% of the total volume of installation)
- \*5 - Safety airvent unit
- \*6 - Thermal safety valve

- \*P1 - Pump P1 (boiler pump)
- \*P2 - Pump P2 (heating pump circuit 2)
- \*P3 - Pump P3 (heating pump circuit 1)
- A - Accumulation tank sensor (upper)
- B - Accumulation tank sensor (lower)
- D - Outer temperature sensor
- E - Flue gas sensor
- F - Main flow temperature sensor
- \*G - Room thermostat
- H - Room corrector (CSK)
- \*I - Heating circuit
- \*J - 3-way mixing valve with motor drive or manual
- 3-way mixing valve
- \*K - Manual 3-way mixing valve

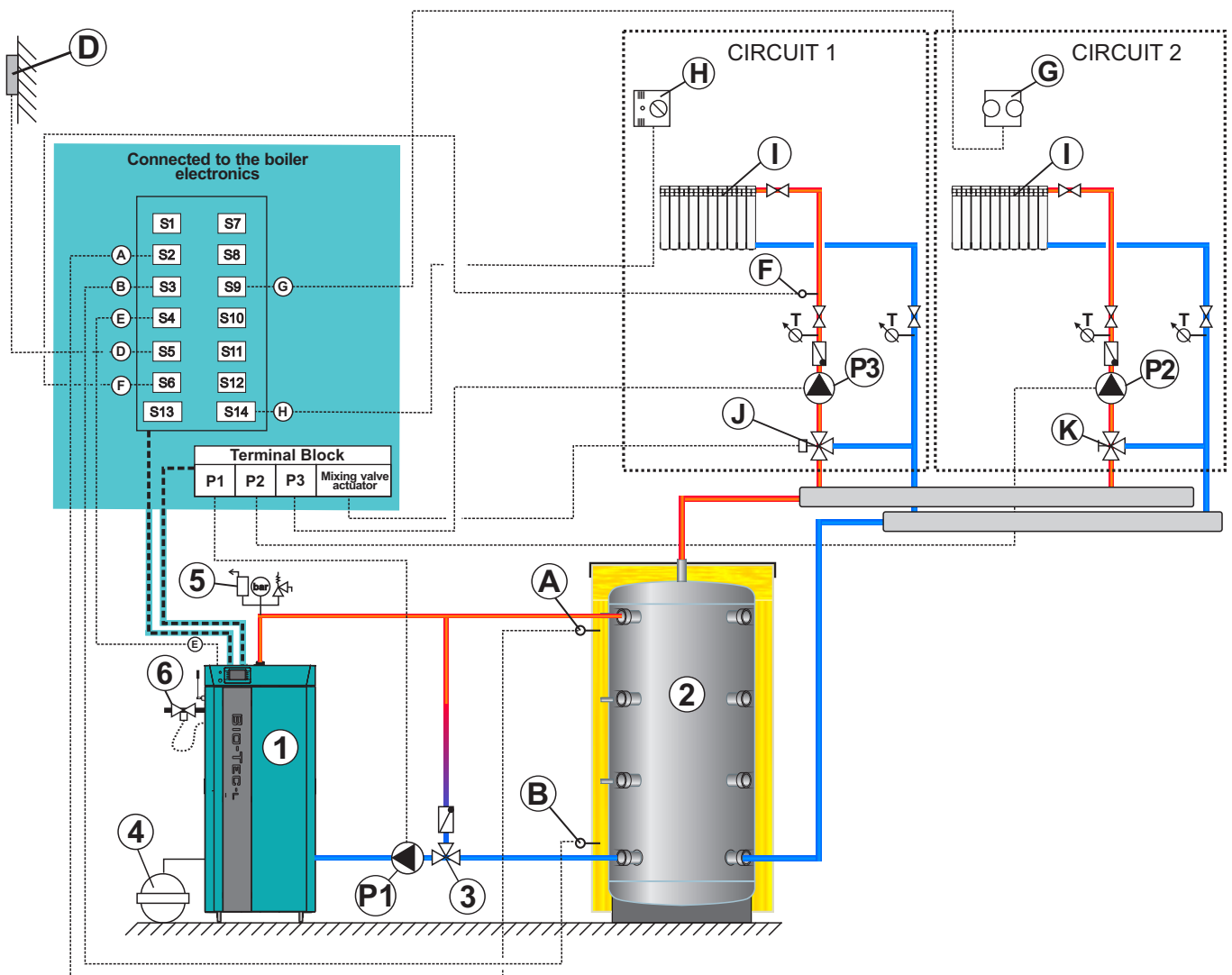

\* Not included in delivery of boiler Biotec-L (need additional order)

**NOTE:**

According to this scheme is possible to preform version with heating system in front accumulation tank.

According to this scheme is possible to preform version for open central heating system (see point 6.0, Connection to the central heating system).

## Scheme 9. - General scheme of closed central heating system with 1 accumulation tank, heating system in front of accumulation tank, 2 heating circuit with 3-way mixing valve, room corrector, room thermostat

- 1 - Boiler "BioTec-L".
- \*2 - "CAS" accumulation tank (buffer tank).
- \*3 - Return flow protection (3-way thermic valve (60°C), VTC 531, LTC 261/271, Laddomat 21 or 3-way mixing valve with motor drive (protection valve))
- \*4 - Expansion vessel for closed systems (min. 10% of the total volume of installation)
- \*5 - Safety airvent unit
- \*6 - Thermal safety valve

- \*P1 - Pump P1 (boiler pump)
- \*P2 - Pump P2 (heating pump circuit 2)
- \*P3 - Pump P3 (heating pump circuit 1)
- A - Accumulation tank sensor (upper)
- B - Accumulation tank sensor (lower)
- D - Outer temperature sensor
- E - Flue gas sensor
- F - Main flow temperature sensor
- G - Room thermostat
- H - Room corrector (CSK)
- I - Heating circuit
- \*J - 3-way mixing valve with motor drive or manual
- \*K - Manual 3-way mixing valve

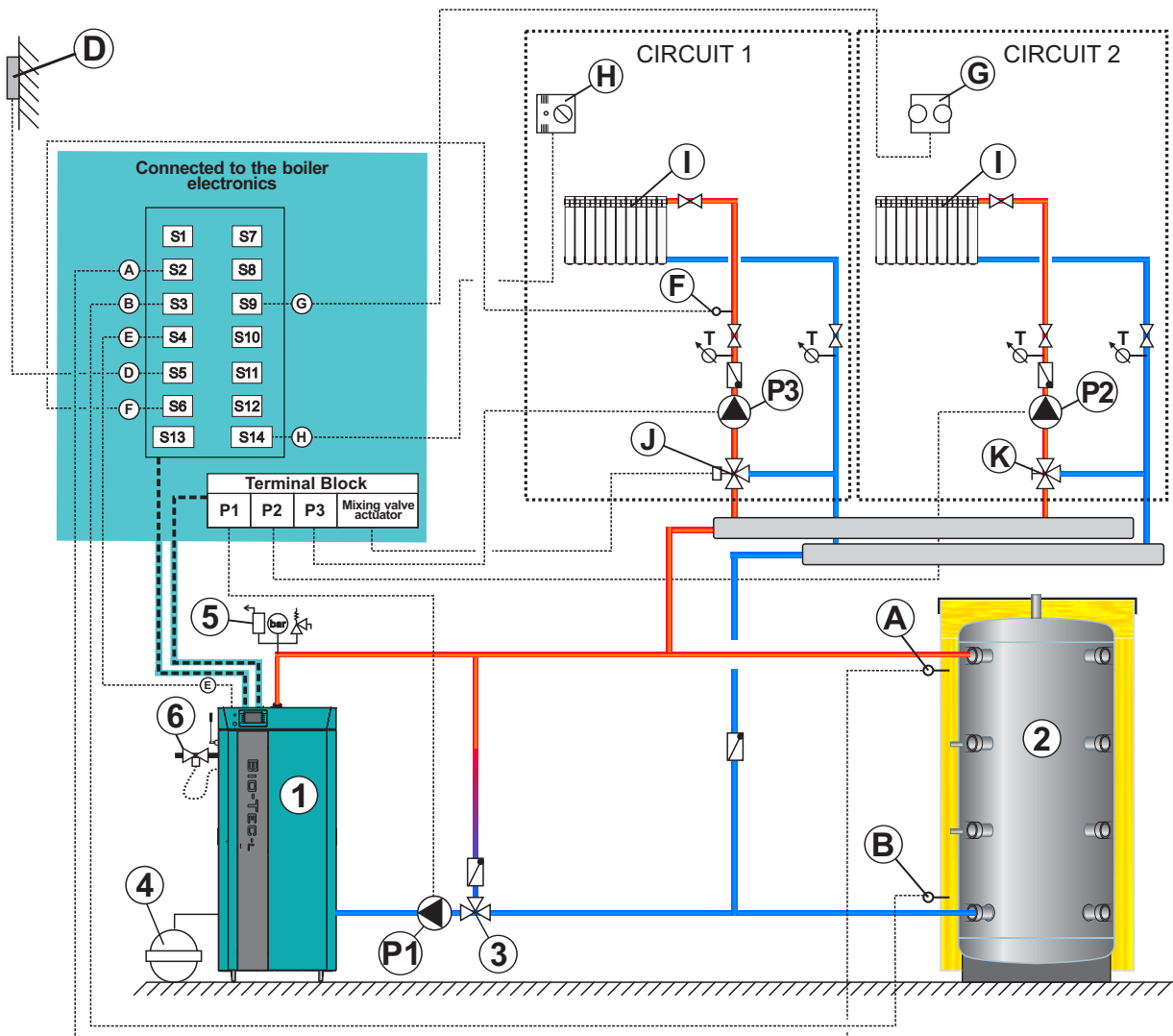

\* Not included in delivery of boiler Biotec-L (need additional order)

### NOTE:

In heating circuit 2 can establish circulation even though P2 doesn't work (under the influence of P1). According to this scheme is possible to preform version for open central heating system (see point 6.0, Connection to the central heating system).



**Scheme 10.** - General scheme of closed central heating system with 1 accumulation tank, heating system behind accumulation tank, 3 heating circuit with 3-way mixing valve and DHW preparing.

- 1 - Boiler "BioTec-L".
- \*2 - "CAS" accumulation tank (buffer tank).
- \*3 - Return flow protection (3-way thermic valve (60°C), VTC 531, LTC 261/271, Laddomat 21 or 3-way mixing valve with motor drive (protection valve)).
- \*4 - Expansion vessel for closed systems (min. 10% of the total volume of installation)
- \*5 - Sanitary water tank (SKB-Digi/LKB-Digi/TB/STEB)
- \*6 - Safety airvent unit
- \*7 - Thermal safety valve
- \*P1 - Pump P1 (boiler pump)
- \*P2 - Pump P2 (DHW pump)
- \*P3 - Pump P3 (heating pump circuit 1)
- A - Accumulation tank sensor (upper)
- B - Accumulation tank sensor (lower)
- C - DHW sensor (domestic hot water)
- D - Outer temperature sensor
- E - Flue gas sensor
- L - Main flow temperature sensor
- H - Room corrector 1 (CSK)
- \*\*F - CM2K-B module (can be expanded to max. 4 units connected in series)
- \*G - 3-way mixing valve with motor drive or manual 3-way mixing valve
- \*H1 - Room corrector 2 (CSK)
- \*H2 - Room corrector 3 (CSK)
- \*I - Heating circuit
- \*\*J - Main flow temperature sensor in circuit CM2K. (**must be** installed with 3-way mixing valve with motor drive)
- \*K - Heating pump (managed by CM2K-B)

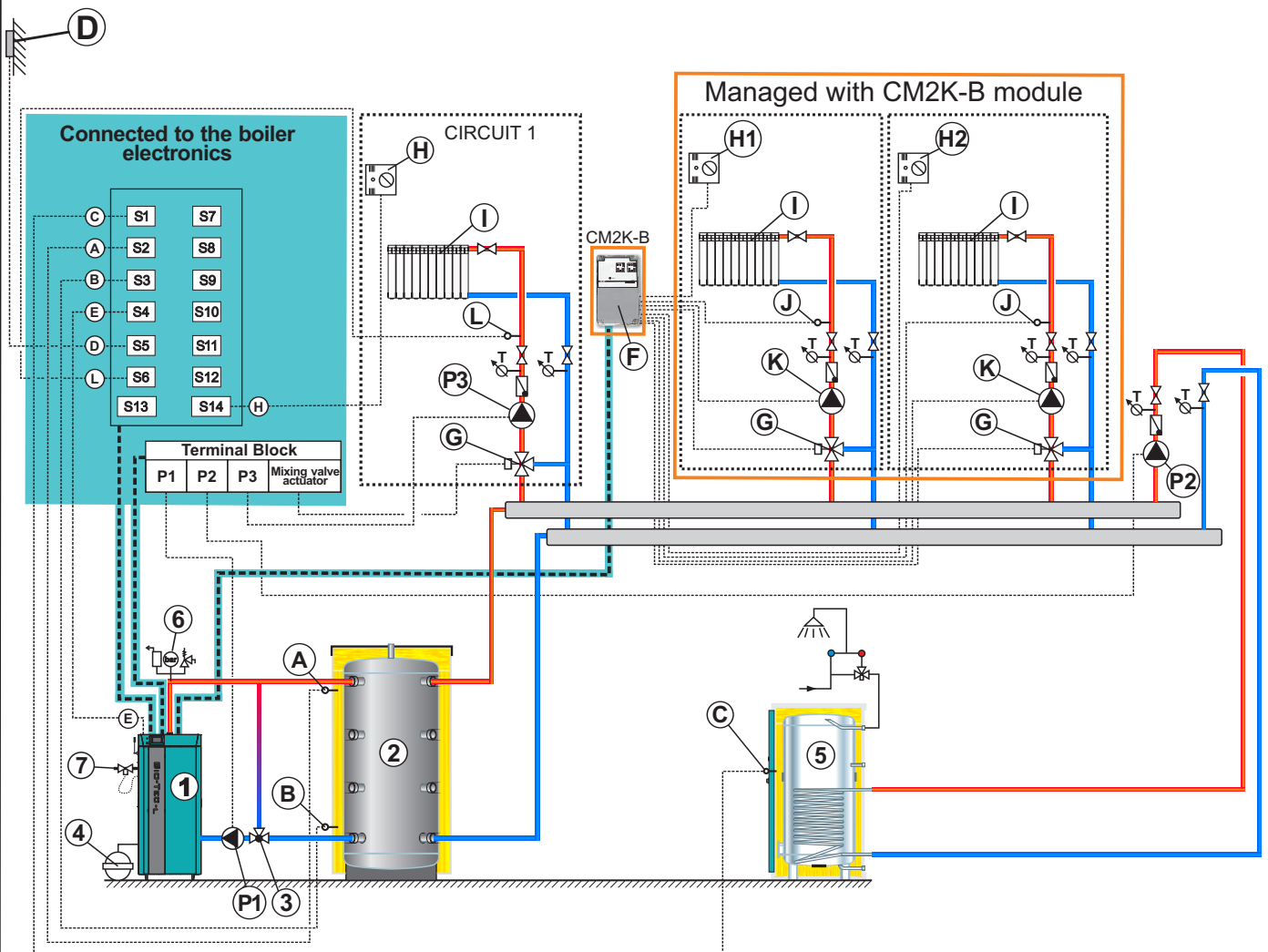

\* Not included in delivery of boiler Biotec-L or CM2K-B module (need additional order)

\*\* Included in basic delivery of CM2K-B module

**NOTE:**

According to this scheme is possible to preform version for open central heating system (see point 6.0, Connection to the central heating system). It's possible to expand system of heating circuit lead by CM2K-B module with installing additional CM2K-B modules (max. 3 pcs) in serial connection.

**Scheme 11** - General scheme of closed central heating system with 1 accumulation tank, hydraulic crossover behind accumulation tank, 2 heating circuits with 3-way mixing valve with motor drive managed by CM2K-B module, DHW preparing.

- 1 - Boiler "BioTec-L".
- \*2 - "CAS" accumulation tank (buffer tank).
- \*3 - Return flow protection (3-way thermic valve (60°C), VTC 531, LTC 261/271, Laddomat 21 or 3-way mixing valve with motor drive (protection valve)).
- \*4 - Expansion vessel for closed systems (min. 10% of the total volume of installation)
- \*5 - Sanitary water tank (SKB-Digi/LKB-Digi/TB/STEB)
- \*6 - Safety airvent unit
- \*7 - Thermal safety valve
- \*8 - Hydraulic crossover

- \*P1 - Pump P1 (boiler pump)
- \*P2 - Pump P2 (DHW pump)
- \*P3 - Pump P3 (hydraulic crossover pump)
- A - Accumulation tank sensor (upper)
- B - Accumulation tank sensor (lower)
- C - DHW sensor (domestic hot water)
- D - Outer temperature sensor
- E - Flue gas sensor
- M - Hydraulic crossover sensor (delivered as flow temperature sensor)

- \*\*F - CM2K-B module (can be expanded to max. 4 units connected in series)
- \*G - 3-way mixing valve with motor drive or manual 3-way mixing valve
- H1 - Room corrector 1 (CSK) (1x room corrector CSK included in basic boiler delivery)
- \*H2 - Room corrector 2 (CSK)
- \*I - Heating circuit
- \*\*J - Main flow temperature sensor in circuit CM2K (**must be** installed with 3-way mixing valve with motor drive)
- \*K - Heating pump (managed by CM2K-B)

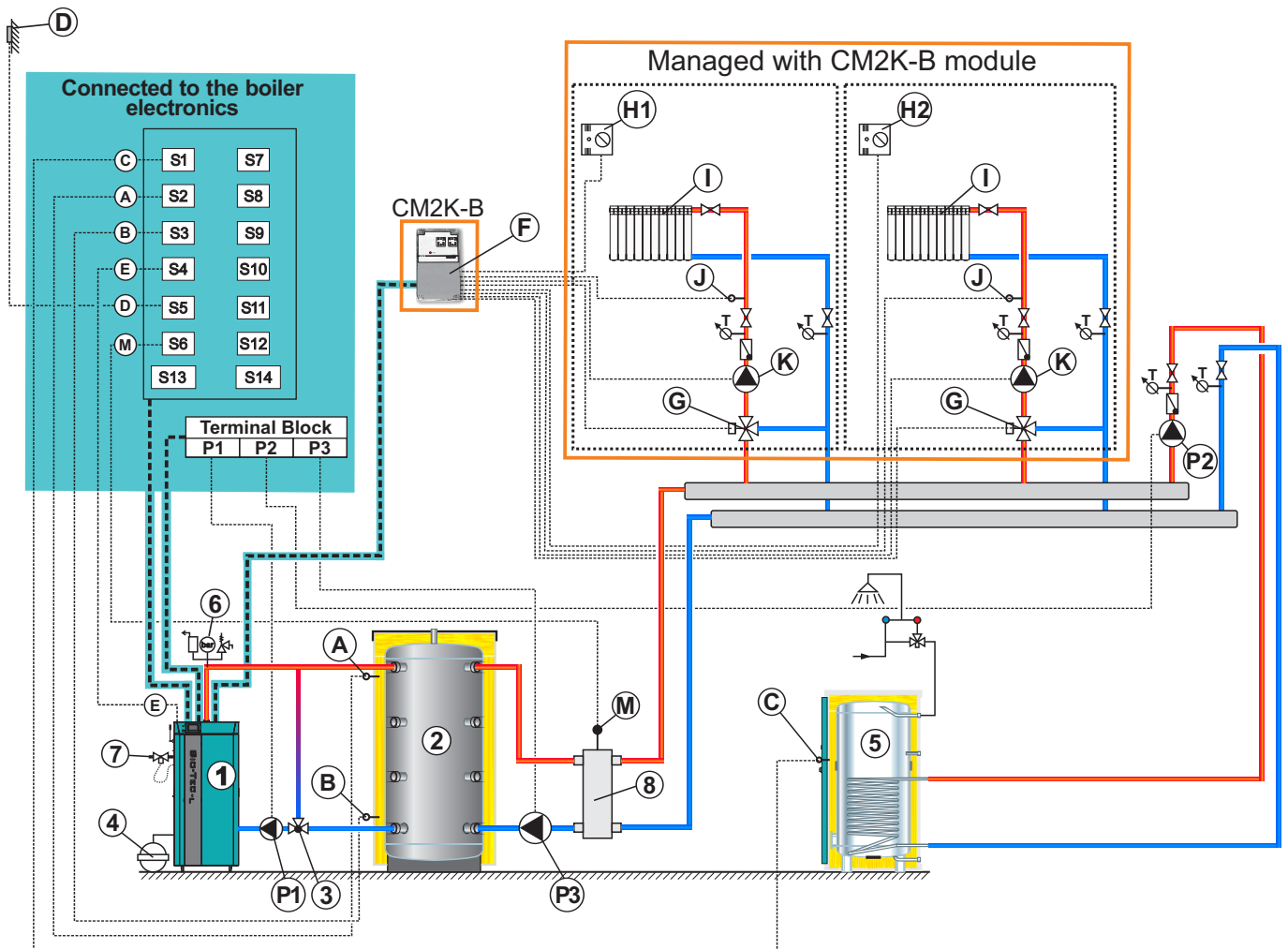

\* Not included in delivery of boiler Biotec-L or CM2K-B module (need additional order)

\*\* Included in basic delivery of CM2K-B module

**NOTE:**

According to this scheme is possible to preform version for open central heating system (see point 6.0, Connection to the central heating system).

It's possible to expand system of heating circuit lead by CM2K-B module with installing additional CM2K-B modules (max. 3 pcs) in serial connection.

**Scheme 12** - General scheme of closed central heating system with 1 accumulation tank, hydraulic crossover behind accumulation tank, 3 heating circuits with 3-way mixing valve with motor drive (1 direct heating circuit and 2 circuits managed by CM2K-B module).

- 1 - Boiler "BioTec-L".
- \*2 - "CAS" accumulation tank (buffer tank).
- \*3 - Return flow protection (3-way thermic valve (60°C), VTC 531, LTC 261/271, Laddomat 21 or 3-way mixing valve with motor drive (protection valve)).
- \*4 - Expansion vessel for closed systems (min. 10% of the total volume of installation)
- \*5 - Hydraulic crossover
- \*6 - Safety airvent unit
- \*7 - Thermal safety valve
- \*P1 - Pump P1 (boiler pump)
- \*P2 - Pump P2 (hydraulic crossover pump)
- \*P3 - Pump P3 (heating circuit 1 pump)
- A - Accumulation tank sensor (upper)
- B - Accumulation tank sensor (lower)
- D - Outer temperature sensor
- E - Flue gas sensor
- L - Main flow temperature sensor (circuit 1)
- M - Hydraulic crossover sensor (delivered as flow temperature sensor)
- \*\*F - CM2K-B module (can be expanded to max. 4 units connected in series)
- \*G - 3-way mixing valve with motor drive or manual 3-way mixing valve
- H1 - Room corrector 1 (CSK) (1x room corrector CSK included in basic boiler delivery)
- \*H2 - Room corrector 2 (CSK)
- \*I - Heating circuit
- \*\*J - Main flow temperature sensor in circuit CM2K (must be installed with 3-way mixing valve with motor drive)
- \*K - Heating pump (managed by CM2K-B)

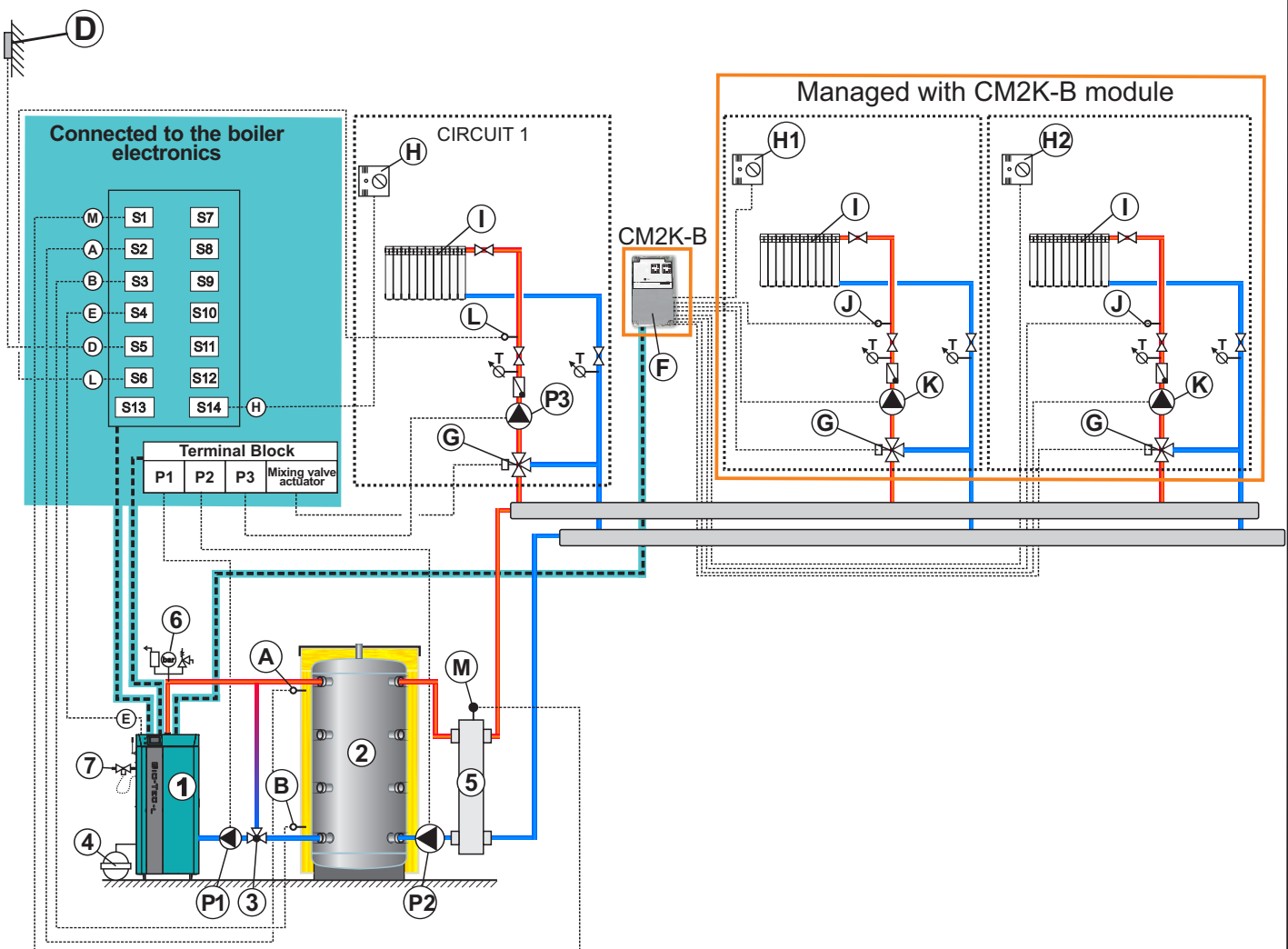

\* Not included in delivery of boiler Biotec-L or CM2K-B module (need additional order)

\*\* Included in basic delivery of CM2K-B module

**NOTE:**

According to this scheme is possible to preform version for open central heating system (see point 6.0, Connection to the central heating system).

It's possible to expand system of heating circuit lead by CM2K-B module with installing additional CM2K-B modules (max. 3 pcs) in serial connection.

## Scheme 13. - General scheme of closed central heating system with 1 accumulation tank, custom heating system

- 1 - Boiler "BioTec-L".
- \*2 - "CAS" accumulation tank (buffer tank).
- \*3 - Return flow protection (3-way thermic valve (60°C), VTC 531, LTC 261/271, Laddomat 21 or 3-way mixing valve with motor drive (protection valve))
- \*4 - Expansion vessel for closed systems (min. 10% of the total volume of installation)
- \*5 - Safety airvent unit
- \*6 - Thermal safety valve

- \*P1 - Pump P1 (boiler pump)
- A - Accumulation tank sensor (upper)
- B - Accumulation tank sensor (lower)
- D - Outer temperature sensor
- E - Flue gas sensor

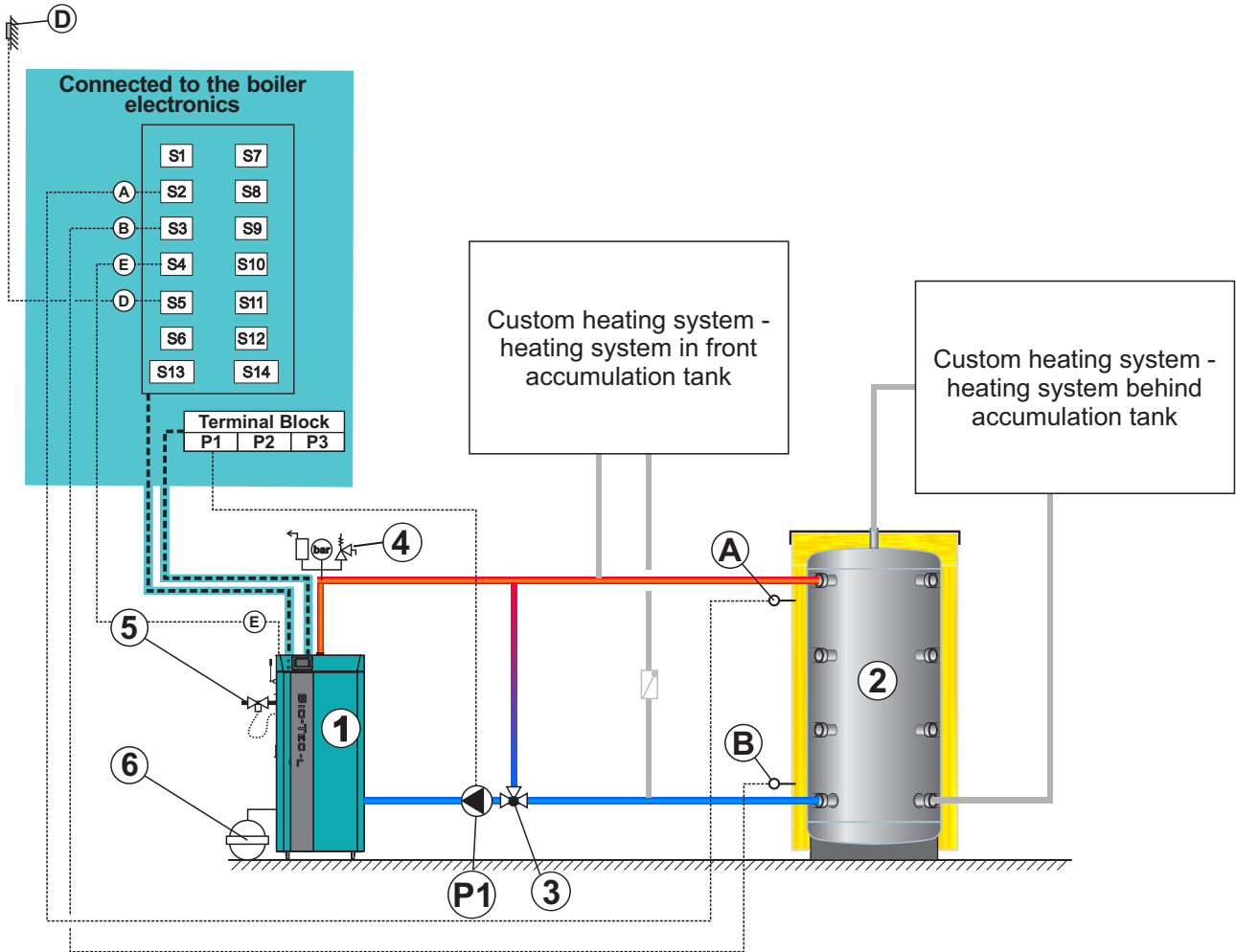

\* Not included in delivery of boiler Biotec-L (need additional order)

### NOTE:

According to this scheme is possible to preform version for open central heating system (see point 6.0, Connection to the central heating system).

## **7.0. BOILER REGULATION**

### **7.1. BOILER CONTROL**

The boiler is controlled with electronic control unit, built in the upper part of the boiler, below upper casing.

Control unit controls boiler functioning, one heat circuit through 3 way mixing valve with actuator and outer temp. sensor and DHW tank. On the front boiler panel are main switch, for switching on/off the boiler control unit, safety thermostat and touch screen of control unit.

**Figure 7.** Boiler electronic

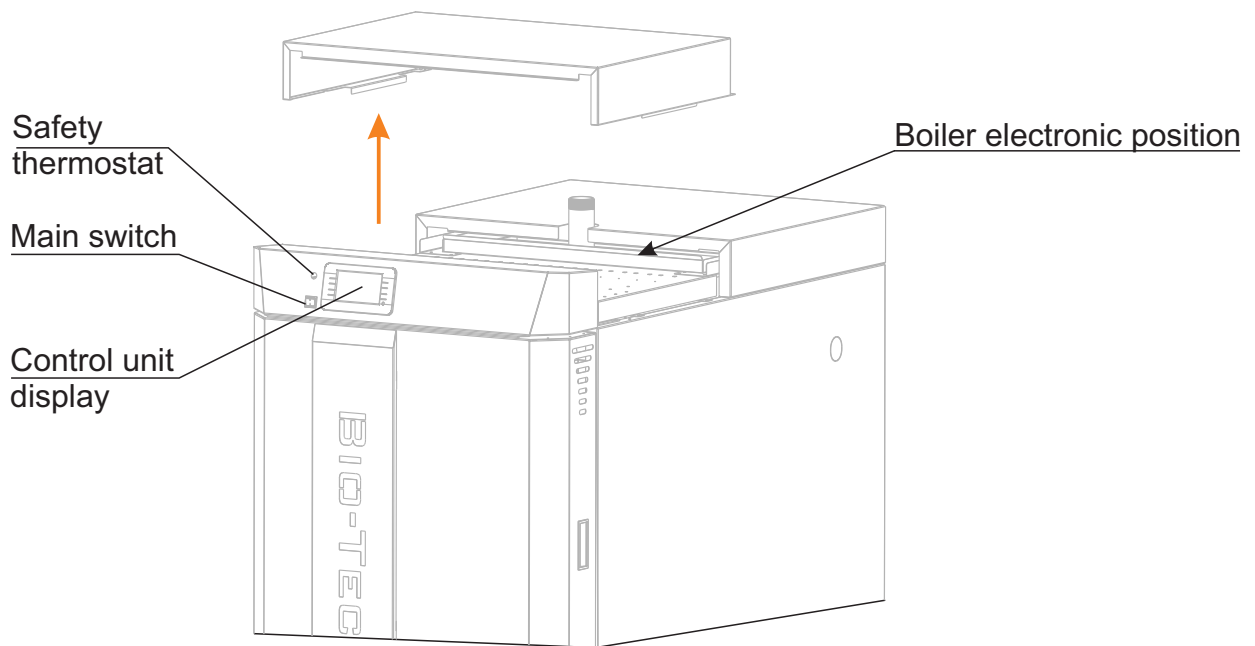

### **7.2. THERMAL PROTECTION OF THE BOILER (obligatory in closed heating system)**

If the boiler is installed in the closed central heating system, a thermal valve must be built to the designed location on the boiler. Thermal valve must be connected to the aqueduct and, if this is not possible, the boiler has to be built in the open heating system.

If, even with inbuilt control elements, boiler temperature reaches the temperature of 95°C, the thermal safety valve shall allow that the water from the aqueduct comes through the thermal valve into the boiler heat exchanger and to cool the boiler down (see point 5.0.).

### **7.3. UPPER DOOR MICROSWITCH**

When upper boiler door are opened, to fill the wood logs, or to check the level of wood in the boiler, microswitch is released. That action gives a signal to controller to put the fan on max. speed (100%) to prevent the smoke to come out of the boiler into the boiler room.

### **7.3. SAFETY PROTECTION IN CASE OF EXCEED TEMPERATURE**

The boiler is equipped with safety thermostat that protects the boiler from overheating. For more information about the safety thermostat see "Description and using of boiler control unit".

## 8.0. ELECTRIC CONNECTION

All electrical works must be performed by a certified professional in accordance with valid national and European standards.

A device for switching of all power supply poles must be installed in electrical installation in accordance with the national regulations on electrical installations.

Detailed description of connecting the sensors and operation of digital regulation is displayed in the Technical manual "Digital boiler control unit BioTec-L".

**⚠ CAUTION:**

When connecting any electrical part be sure to unplug the boiler at the main switch and disconnect the power supply.

S1	S7
S2	S8
S3	S9
S4	S10
S5	S11
S6	S12

S13      S14

- S1 - Sanitary water / hydraulic crossover sensor\*
- S2 - Accumulation tank 1 sensor (up)
- S3 - Accumulation tank 2 sensor (down)
- S4 - Flue gas sensor
- S5 - Outer sensor
- S6 - Main flow sensor / hydraulic crossover sensor\*
- S7 - Return flow sensor
- S8 - Not used
- S9 - Room thermostat
- S10 - Alarm output 1 (Additional equipment)
- S11 - Alarm output 2 (Additional equipment)
- S12 - Not used
- S13 - Not used
- S14 - Room corrector

\*If the configuration contains hydraulic crossover, delivered main flow temperature sensor or sanitary water sensor becomes hydraulic crossover sensor, depending on other elements of the configuration. When configuration contains hydraulic crossover along DHW tank or heating circuit, then hydraulic crossover temp. sensor must be connected to connector S6, in other cases hydraulic crossover temp. sensor must be connected to the connector S1.

### Terminal Block & Strip Connector

N L	N L	N L	N L	N	N L  L1	Red	Black	White
Power supply 230 V	Pump P1	Pump P2	Pump P3	Mixing valve actuator	Fan	RPM Counter		

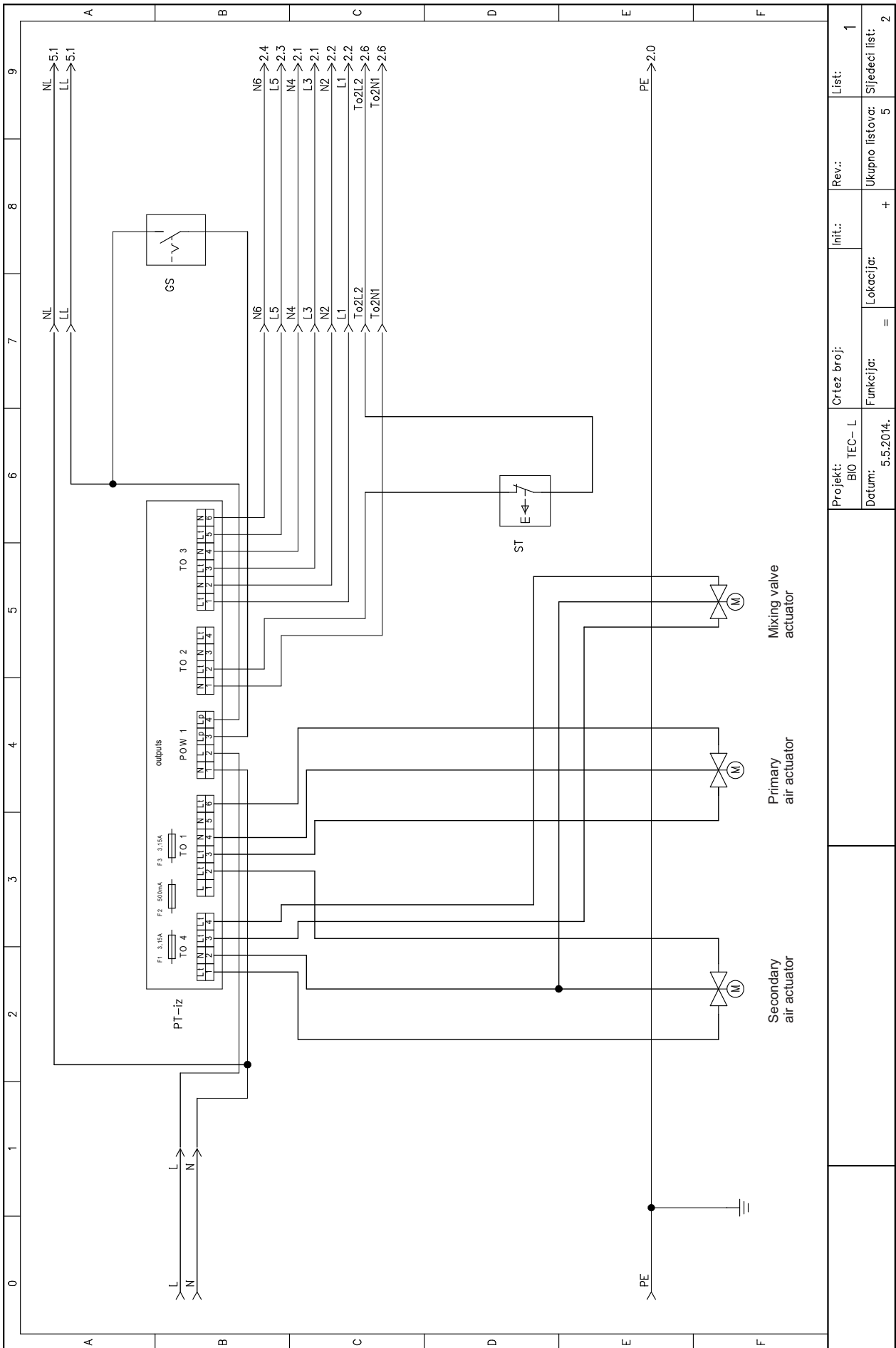

Projekt:	BIO TEC- L	Crtez broj:		Init.:		Rev.:		List:	1
Datum:	5.5.2014.	Funkcija:	=	Lokacija:		Ukupno listova:	5	Sijedeci list:	2

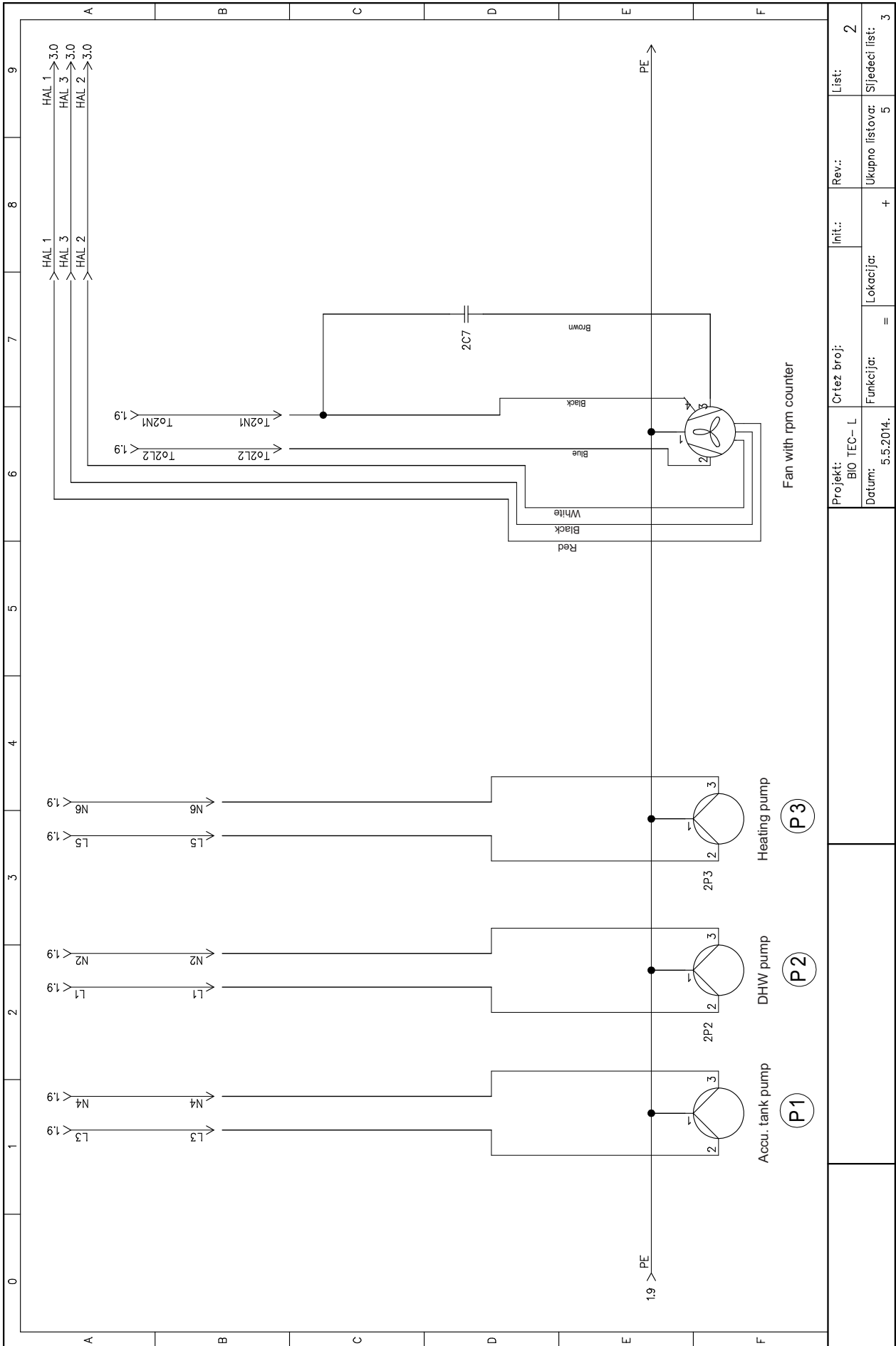

Projekt:	BIO TEC- L	Crtez broj:		Init.:		Rev.:		List:	2
Datum:	5.5.2014.	Funkcija:	=	Lokacija:		Ukupno listova:	5	Sijedeci list:	3



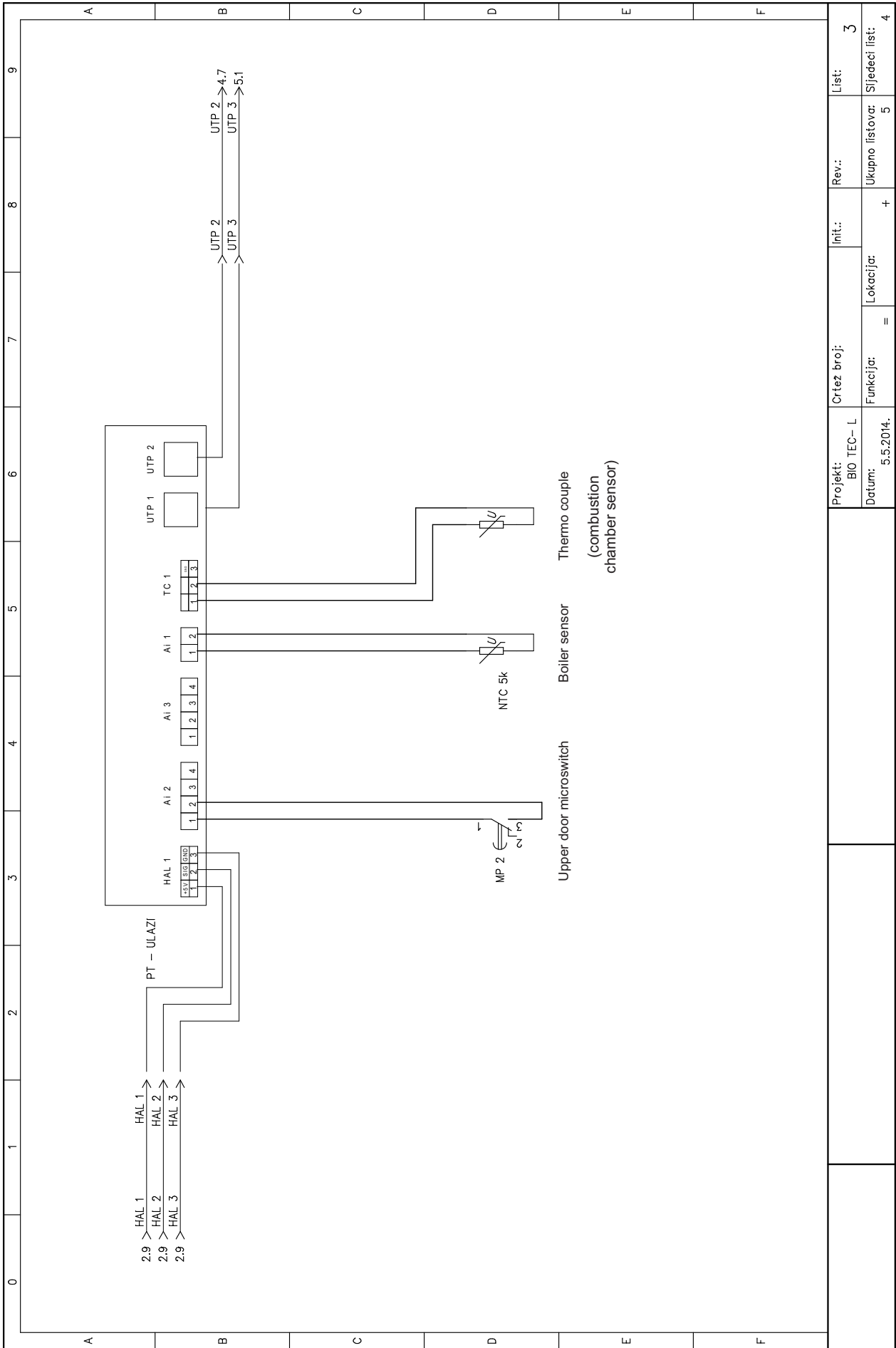

Projekt:	BIO TEC- L	Crtez broj:		Init.:		Rev.:		List:	3
Datum:	5.5.2014.	Funkcija:	=	Lokacija:		Ukupno listova:	5	Sijedeci list:	4

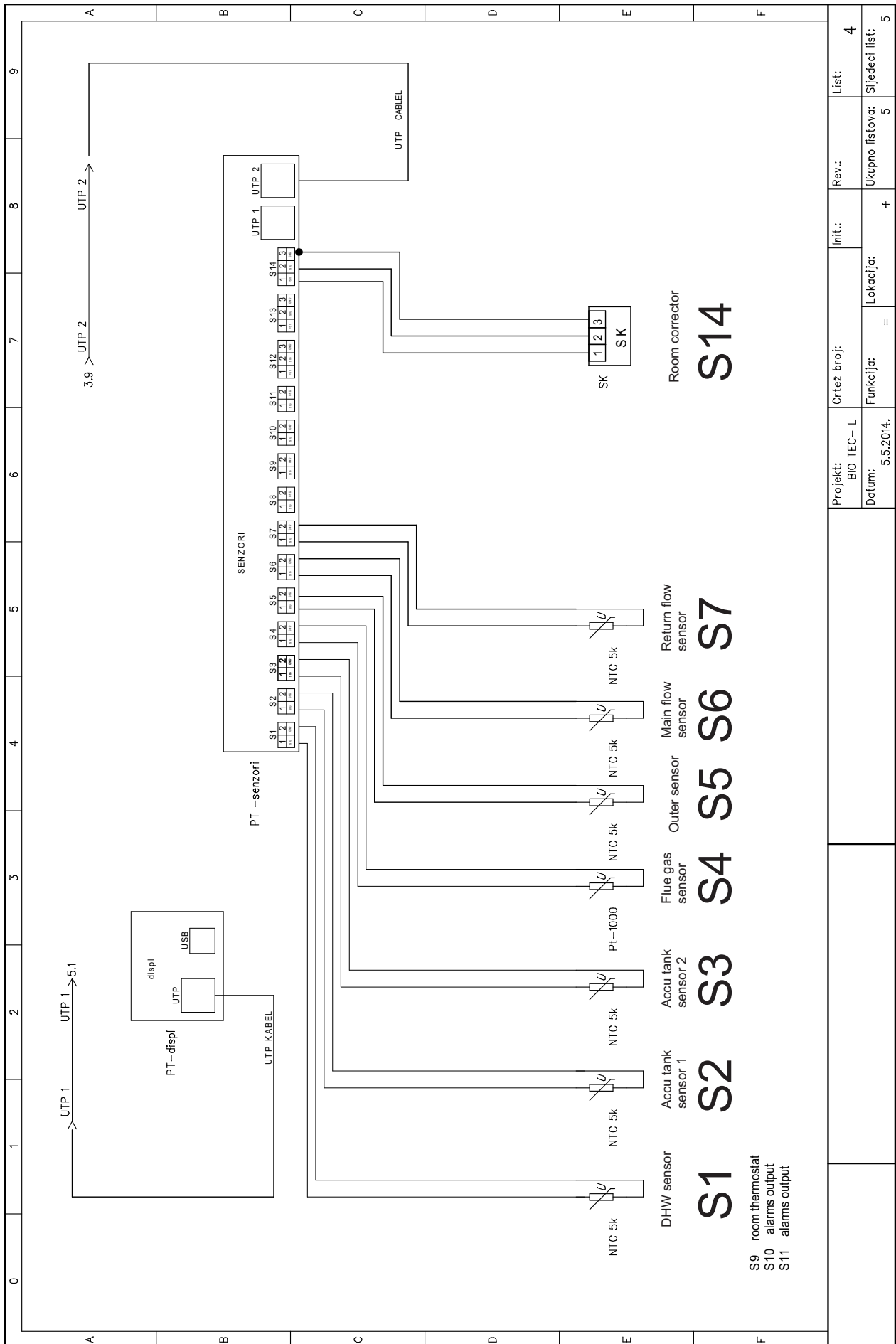

Projekt:	BIO TEC- L	Crtez broj:	Init.:	Rev.:	List:
Datum:	5.5.2014.	Funkcija:	=	Ukupno listova:	5
			Lokacija:	+	Sijedeci list:
					5

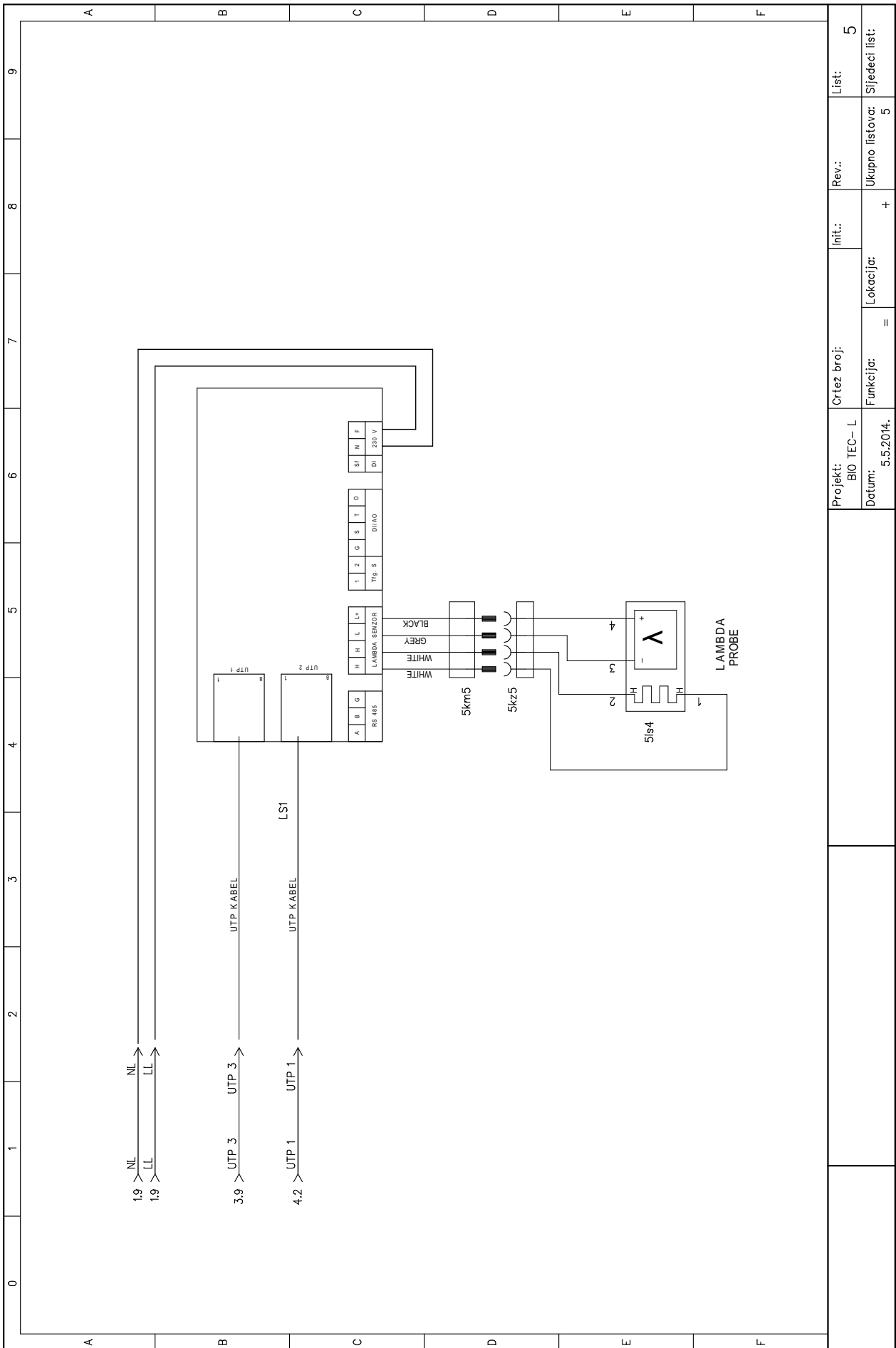

Projekt:	BIO TEC- L	Crtez broj:		Init.:		Rev.:		List:	5
Datum:	5.5.2014.	Funkcija:	=	Lokacija:		Ukupno listova:	+	Sjedeci list:	5

8.1. BOILER SENSORS AND PROBES

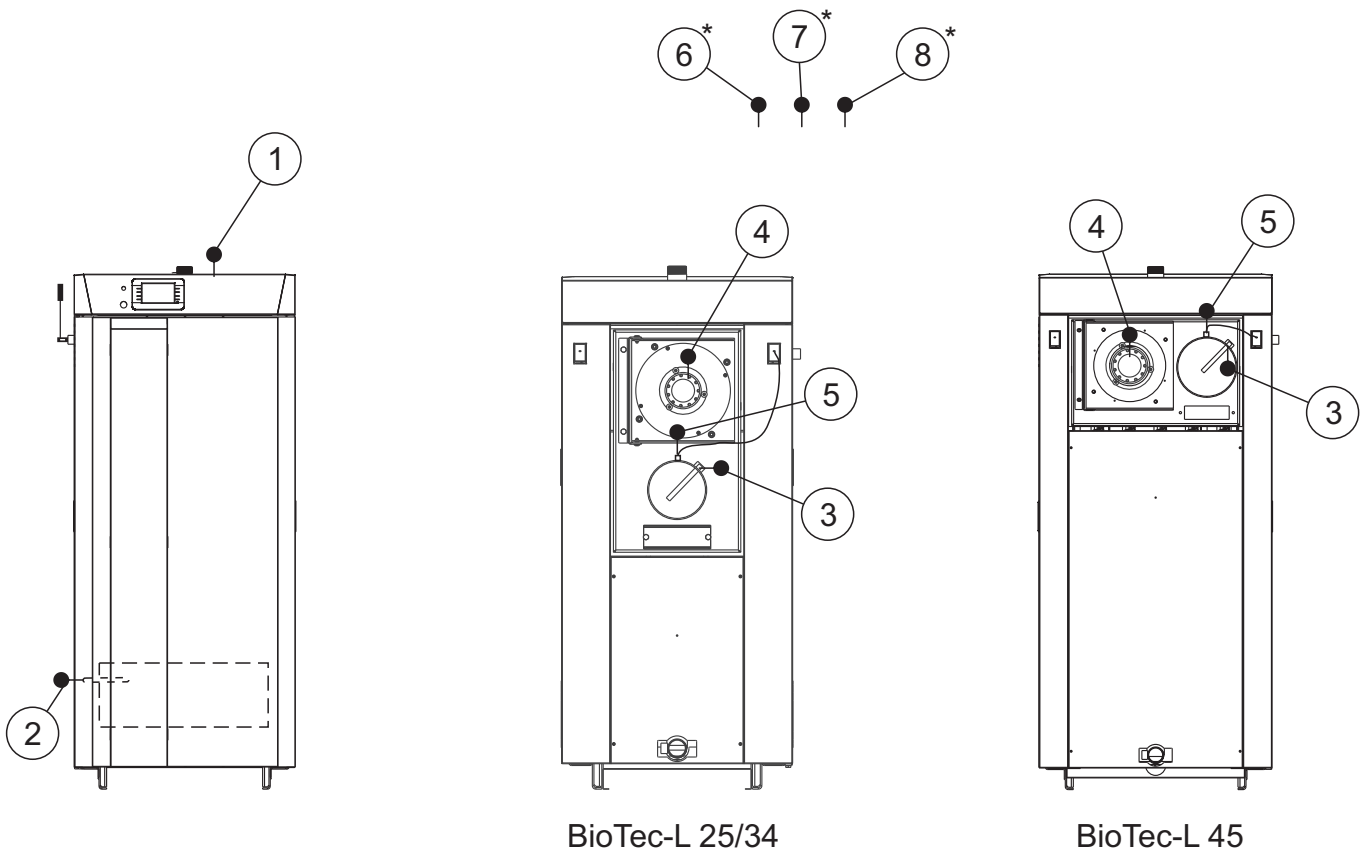

- ① - Boiler sensor (NTC 5k)
- ② - Combustion chamber temperature sensor (thermo couple)
- ③ - Flue gas sensor (Pt1000)
- ④ - Fan speed sensor
- ⑤ - Lambda probe
- ⑥ - Outer temperature sensor (NTC5k)
- ⑦ - Main flow temperature sensor / Return flow temperature sensor (NTC5k)
- ⑧ - Domestic hot water (DHW) temperature sensor (NTC5k)

\* - On heating installation

**RESISTANCE LIST NTC Pt1000 SENSOR**  
(measuring field -30 - +400 °C)

Temperature (°C)	Resis. (Ω)	Temperature (°C)	Resis. (Ω)
-30	885	225	1.866
-25	904	230	1.886
-20	923	235	1.905
-15	942	240	1.924
-10	962	245	1.943
-5	981	250	1.963
0	1.000	255	1.982
5	1.019	260	2.001
10	1.039	265	2.020
15	1.058	270	2.040
20	1.077	275	2.059
25	1.096	280	2.078
30	1.116	285	2.097
35	1.135	290	2.117
40	1.154	295	2.136
45	1.173	300	2.155
50	1.193	305	2.174
55	1.212	310	2.194
60	1.231	315	2.213
65	1.250	320	2.232
70	1.270	325	2.251
75	1.289	330	2.271
80	1.308	335	2.290
85	1.327	340	2.309
90	1.347	345	2.328
95	1.366	350	2.348
100	1.385	355	2.367
105	1.404	360	2.386
110	1.424	365	2.405
115	1.443	370	2.425
120	1.462	375	2.444
125	1.481	380	2.463
130	1.501	385	2.482
135	1.520	390	2.502
140	1.539	395	2.521
145	1.558	400	2.540
150	1.578		
155	1.597		
160	1.616		
165	1.635		
170	1.655		
175	1.674		
180	1.693		
185	1.712		
190	1.732		
195	1.751		
200	1.770		
205	1.789		
210	1.809		
215	1.828		
220	1.847		

**RESISTANCE LIST NTC 5k/25°C SENSOR**  
(measuring field from -20 - +130 °C)

Temperature (°C)	Resistance (Ω)
-20	48.534
-15	36.465
-10	27.665
-5	21.158
0	16.325
5	12.694
10	9.950
15	7.854
20	6.245
25	5.000
30	4.028
34	3.266
40	2.663
45	2.184
50	1.801
55	1.493
60	1,244
65	1.041
70	876
75	740,7
80	629,0
85	536,2
90	458,8
95	394,3
100	340,0
105	294,3
110	255,6
115	222,7
120	190,7
125	170,8
130	150,5

## 9.0 CLEANING AND MAINTENANCE OF THE BOILER

Every millimeter of soot and dirt on the surfaces of the boiler surface means approx. 5% higher fuel consumption.

**Save fuel** – clean the boiler on time!



**PROTECTIVE GLOVES ARE OBLIGATORY!!!**



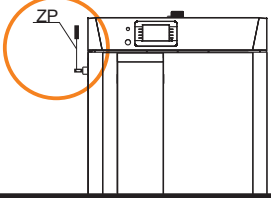

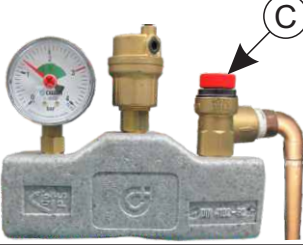
Cleaning / maintenance interval	Boiler type	Description
Before each ignition	25, 34 and 45 kW	Cleaning top and bottom firebox area (middle and lower doors)
<p>Before every ignition is necessary to clean area below firebox and lower refractory stone (DS) (through middle and lower boiler door (DV)). Before cleaning is necessary to turn on option "cleaning". Fan will work at maximum speed to reduce the spread of dust to the room. When you finish cleaning, press the "STOP" button. If time of 30:00 minutes has expired cleaning option (fan) will automatically turn off.</p>		
<div style="display: flex; justify-content: space-between;"> <div style="width: 48%;"> <p><b>1</b></p> </div> <div style="width: 48%;"> <p><b>2</b></p> </div> </div>		
<div style="display: flex; justify-content: space-between;"> <div style="width: 48%;"> <p><b>3</b></p> </div> <div style="width: 48%;"> <p><b>4</b></p> </div> </div>		
<ol style="list-style-type: none"> <li>1. Press button "Cleaning" on main screen</li> <li>2. Press button "OK"</li> <li>3. Open front boiler door (VI).</li> <li>4. Open middle boiler door</li> <li>5. Open lower boiler door (DV).</li> <li>6. Insert the ashtray under lower door and use scraper to clean refractory stone(DS) and push ash on the astray.</li> <li>7. Place ash tray below lower boiler door and clean space in and around lower chamotte (DS). It's important to cleane metal sides of lower firebox. Put ash to ash tray.</li> <li>8. Empty ashtray</li> <li>9. After cleaning, the boiler is ready for ignition.</li> </ol>		

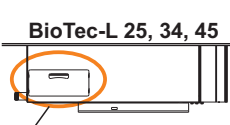
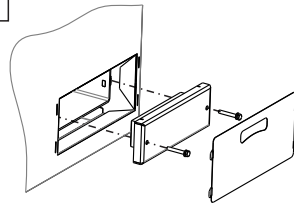
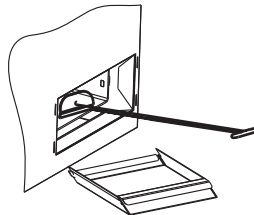
Cleaning / maintenance interval	Boiler type	Description
Before refilling of fuel / before ignition	25, 34 and 45 kW	Flue gas tubes cleaning
 <p>For flue gas tubes cleaning in necessary to pull lever (ZP) few times.</p>		

Cleaning / maintenance interval	Boiler type	Description
Every 6 months	25, 34 and 45 kW	Check the correctness of security valve
 <p><b>Checking the correctness of security valve</b></p> <p>By briefly turning the cap of safety valve (C) check whether water coming out from the safety valve. If no water comes out after several repeated checks, then is necessary to replace the safety valve.</p>		

Cleaning / maintenance interval	Boiler type	Description
At least once per year.	25, 34 and 45 kW	Cleaning of flue gas chamber.
<div style="display: flex; justify-content: space-around;"> <div style="border: 1px solid black; padding: 5px; width: 30%;"> <p><b>1</b></p>  <p>BioTec-L 25, 34, 45</p> <p>Lateral openings for cleaning the flue gas chamber (on left and right side)</p> </div> <div style="border: 1px solid black; padding: 5px; width: 30%;"> <p><b>2</b></p>  </div> <div style="border: 1px solid black; padding: 5px; width: 30%;"> <p><b>3</b></p>  </div> </div> <p>1 - Switch off the boiler and disconnect from electric. power.                  2 - Before cleaning flue gas chamber, pull lever (ZP) few times (see "flue gas tubes cleaning")                  3 - Take out insulation cover, unscrew two screws which hold door of flue gas chamber. This procedure is the same for the other side of the boiler                  4 - Insert ashtray and clean the flue gas chamber with scraper.                  5 - Put the doors and insulation cover to original position.</p> <p><b>Note: For the proper operation of the boiler it is IMPORTANT to hard tight the doors how it to seal perfectly!</b></p> <div style="display: flex; align-items: center; margin-top: 10px;">  <div style="background-color: yellow; padding: 5px; border: 1px solid black;"> <p><b>Before this procedure be sure to disconnect boiler from electric. power!!!</b></p> </div> </div>		

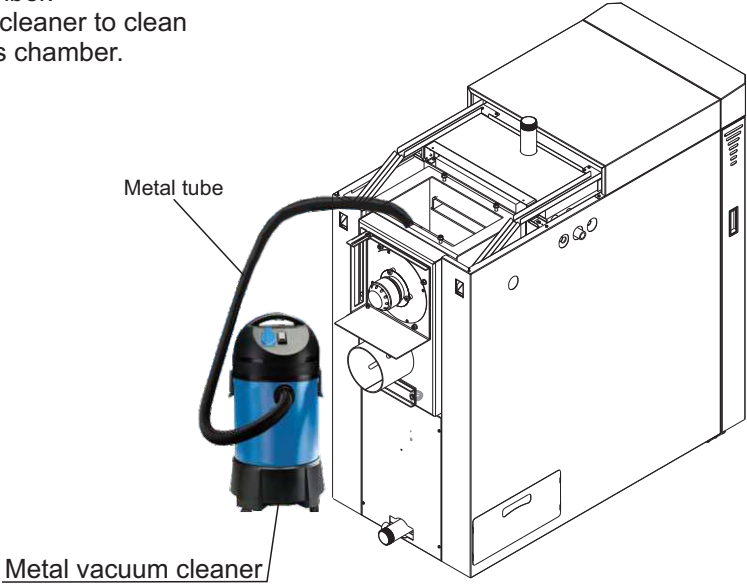
Cleaning / maintenance interval	Boiler type	Description
At least once per year	25, 34 and 45 kW	Cleaning and checking the flue installation sealing
<p><b>Cleaning and checking the flue installation sealing</b></p> <p>Clean flue installation between the boiler and the chimney through the revision openings for cleaning or if not incorporated revision opened by removing the flue installation. After cleaning, inspect flue installation good sealing and seal it if the seal is not satisfactory.</p>		
<div style="display: flex; align-items: center;">  <div style="background-color: yellow; padding: 5px; border: 1px solid black;"> <p><b>Before this procedure be sure to disconnect boiler from electric. power!!!</b></p> </div> </div>		

Cleaning / maintenance interval	Boiler type	Description
At least once per year	25, 34 and 45 kW	Cleaning of area over heat exchanger pipes with turbulators
<p>1 - Switch off the boiler and disconnect from electric. power.                  2 - Take out last upper cover side.                  3 - Open the flue gas chamber.                  4 - Use the metal vacuum cleaner to clean dust and ash in flue gas chamber.</p>		
 <p style="margin-left: 100px;">Metal tube</p> <p style="margin-left: 100px;">Metal vacuum cleaner</p>		
<div style="display: flex; align-items: center;">  <div style="background-color: yellow; padding: 5px; border: 1px solid black;"> <p><b>Before this procedure be sure to disconnect boiler from electric. power!!!</b></p> </div> </div>		



## Cleaning and maintenance of the boiler

Cleaning / maintenance interval	Boiler type	Description
At least once per year	25, 34 and 45 kW	Cleaning the blades and box of the fan

### BioTec-L 25 / 34

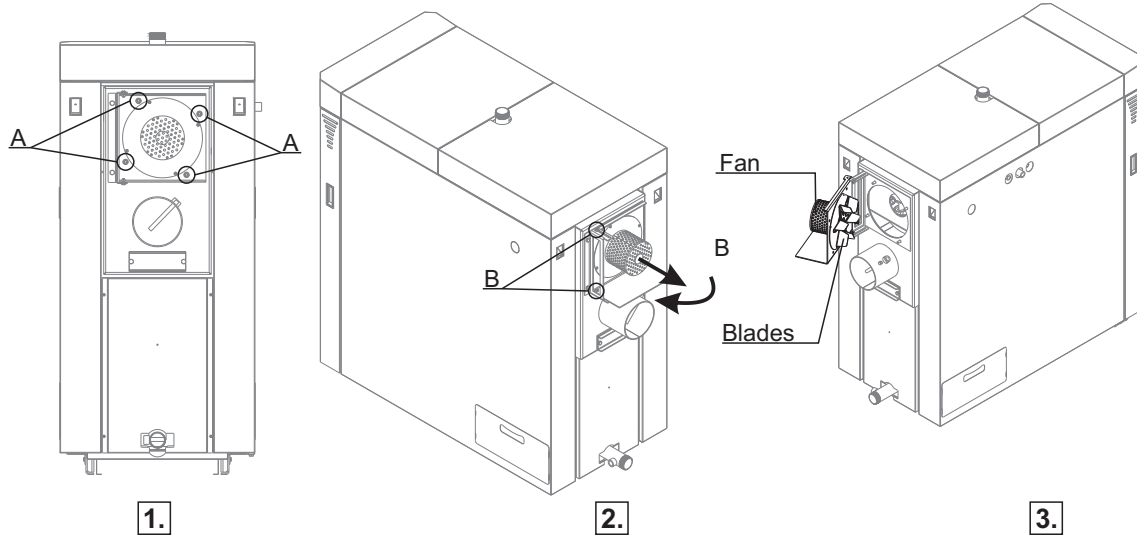

1. Switch off the boiler and disconnect from electric. power.
2. Release nuts (A) shown in Image 1.
3. Release screws (B) shown in Image 2.
4. Pull out fan with flange to the end of rail, then open it to left side (see Image 2. and Image 3.).

### BioTec-L 45

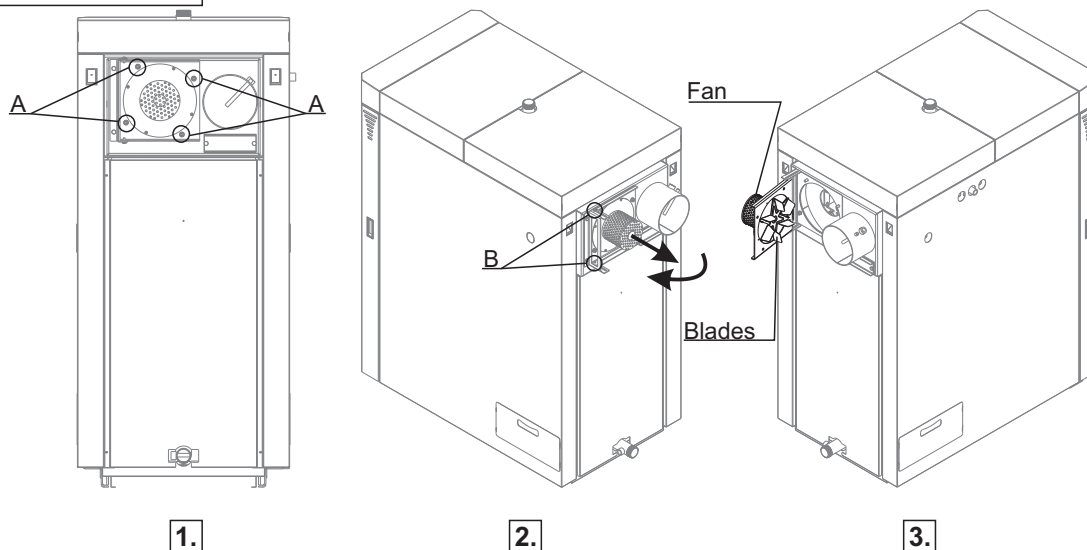

1. Switch off the boiler and disconnect from electric. power.
2. Release nuts (A) shown in Image 1.
3. Release screws (B) shown in Image 2.
4. Pull out fan with flange to the end of rail, then open it to left side (see Image 2. and Image 3.).



**Before this procedure be sure to disconnect boiler from electric. power!!!**

## 10. EXTRACTION OF TURBULATORS

- 1 - Switch off the boiler and disconnect from electric. power.
- 2 - Take out last upper cover side.
- 3 - Release 4 nuts and open the flue gas chamber.
- 4 - Release 2 screws of turbulator axle and pull out turbulators.

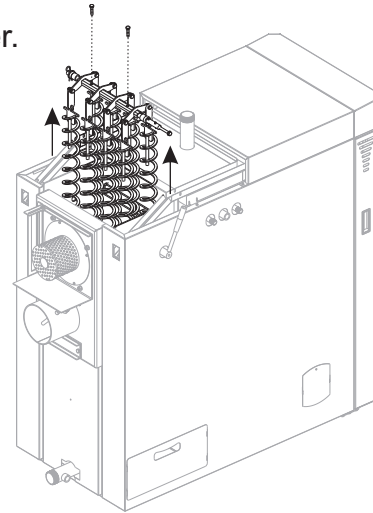

### 10.1 DESCRIPTION OF EXTRACTION THE INSERT FROM TURBULATORS

Removing the insert from the turbulators is carried out in case of condensation in the chimney and due to increase of the flue gas temperature and attempt to prevent condensation.

This will increase the flue gas temperature (in boiler operation) and probably prevent further chimney condensate. In order to remove the insert from the turbulators is necessary to unscrew the screw and nut (A) and Pull the insert (B) from the bottom.

**PROTECTIVE GLOVES ARE OBLIGATORY!!!**



Turbulator with insert.

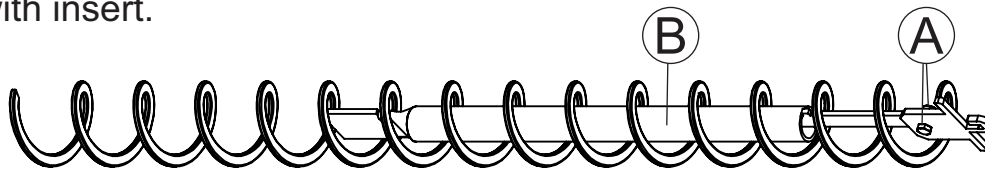

Extracted insert.

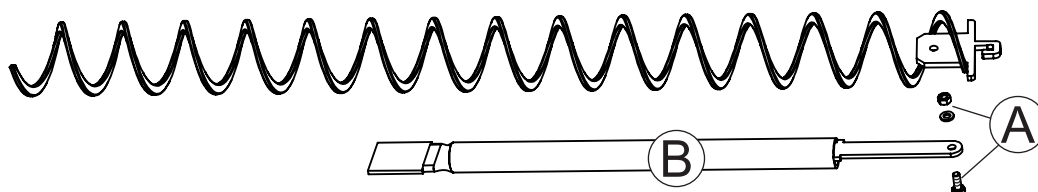

**We do not recommend this action until you used all other methods for preventing condensation in the chimney because this reduces boiler efficiency. Number of turbulators from which inserts been removed is determined by authorized person on a case-by-case basis.**

**This procedure must be done only by authorized person!**

## EC IZJAVA O SUKLADNOSTI EC DECLARATION OF CONFORMITY

Proizvođač

Manufacturer:

Centrometal d.o.o.

Naziv i adresa

Name and address:

HR-40306 Macinec, Glavna 12, Croatia

***punom odgovornošću izjavljuje, da*****We declare under our sole responsibility that**

proizvod

Product designation:

Toplovodni kotao za loženje drvom (za ručno loženje)

tip / model

Type / model:

Hot-water boiler burning wood (with manual fuel supply)

**BioTec – L 25, BioTec – L 34, BioTec – L 45*****odgovara zahtjevima slijedećih propisa*****is in conformity with the provisions of the following regulations**

- |    |   |
|----|---|
| 1. | Pravilnik o sigurnosti strojeva ("Narodne novine", br.028/2011.)<br>MD Directive 2006/42/EC and its amendments  |
| 2. | Pravilnik o tlačnoj opremi ("Narodne novine", br.58/2010.)<br>PED Directive 97/23/EC and its amendments   |
| 3. | Pravilnik o električnoj opremi namijenjenoj za uporabu unutar određenih naponskih granica ("Narodne novine", br.135/2005.)<br>LVD Directive 2006/95/EC and its amendments |
| 4. | Pravilnik o elektromagnetskoj kompatibilnosti ("Narodne novine", br.16/2005.)<br>EMC Directive 2004/108/EC and its amendments   |

***i također zadovoljava zahtjeve slijedećih standardi*****and also complies with the following standards**

Directive 2006/95/EC	EN 60335-1:2002+A1:2004+A11:2004+ A12:2006+A2:2006
Directive 2004/108/EC	EN 55014-1:2000+A1:2001+A2:2002, EN 55014-2:1997 A1:2001, EN 61000-3-2:2000+A2:2005, EN 61000-3-3:1995+ A1:2001+A2:2005
	EN 303-5:2012

**Godina izdavanja CE oznake**  
**Year of affixing of CE marking**

2014.

**Mjesto i vrijeme izdavanja**  
**Place and date of issue**

Macinec, 10.09.2014.

**Ime, prezime i potpis ovlaštene osobe**  
**Name, surname and signature of authorized person**

Tihomir Zidarić

**Centrometal** d.o.o.  
 3 MACINEC, Glavna 12  
 Centrometal 040/872-800; Fax: 372-611



---

### **IMPORTANT !**

- ▶ The fuel to be used is only wood logs under 25% humidity content (wood dried min. 1 year).
- ▶ The return flow temperature always has to be over 60°C. This can be reached by obligatory connection of the 3-way thermic valve ESBE VTC 512 (60°C), VTC 531 (60°C), LTC 141 (60°C), Laddomat 21 (63°C) or 3-way mixing valve with motor drive (protection valve), which blocks the boiler temperature fall under the 60°C level. The return flow temperature protection can be also made by installation of 3-way mixing valve with el. actuator.
- ▶ The connection of CAS water accumulators is obligatory. It is recommended to connect min. 50 liters water accumulation to each 1 kW of boiler power (see local regulation).
- ▶ To the closed central heating system an expanding vessel has to be connected (the volume of the expanding vessel is about 10% of the installation volume).
- ▶ To the open central heating system an open expanding vessel has to be connected (OPC), which volume has to be about 7% of the installation volume.

Centrometal d.o.o. shall not be responsible for possible incorrect data caused by printing errors or error made in transcription and all figures and diagrams are for explanatory purposes only and relevant adjustment have to be made at the spot. In any case, it reserves the right to modify its products as deemed to be required and useful without any prior notification.

**Centrometal d.o.o. Glavna 12, 40306 Macinec, Croatia**

central tel: +385 40 372 600, fax: +385 40 372 611

service tel: +385 40 372 622, fax: +385 40 372 621

**Centrometal**  
HEATING TECHNIQUE